





List of contents

GENERAL MATTERS 	
General matters / Safety-related information / Intended purpose / Developer & manufacturer	3
Rating plate / Transport	4
Commissioning fireproof distribution boards	5
Functional test, care and maintenance, safety-related check	5
Locking mechanisms	6
ASSEMBLY INSTRUCTIONS 	
Free-standing distribution board: LS/CS/FSE/AV/SV/MAXX/DBV/CNV/Violution S-30/S-90	7
Wall distribution board: LW / CW / FWE / Violution W-30	8
Assembly videos: free-standing / wall distribution boards	8
Violution system: Violution W-90	9
Safety cabinet: CGS	10
Wall attachment doors / add-on enclosures: LWA / LWÜ / LWA-E / VIOPARUM	11-22
Inspection doors: CWA-R / LWA-R / LWA-E-R / LEG-R	23-33
Small distribution boards: CK / CV	34
Assembly / Using the fireproof cable entry point	35
Cable entry point for the LWÜ series – add-on enclosures / Cable box: Violution 90	36-38
Duct connecting piece	39-43
EQUIPMENT & ENHANCEMENTS 	
Setting up a metal base	44-45
Setting up a base: Violution 90	46-47
Using the height-adjustable base / ventilation system (KLS)	48
Ventilation system CLS (80 mm) and KLS/VLS (40 mm, optional 80 mm) / connection (rpm)	49
Assembling the outer fan (high-performance fan) / Outer fan Assembly set for DVS - fan	50-52
Assembling the inner fan (12V/24V/230V)	53
Assembling the outer fan LLG 1 fan	54
Assembling the outer fan RLS 230V	55-56
Fans and their key technical data	57
Assembling smoke alarm – slider system	58
Design, operations, operating principle	59
Additional equipment and accessories	59
Crystal-CEL fireproof cement	60
MAINTENANCE & CHECKS 	
Celsion type fire-resistant distribution boards – maintenance checklist for models List for measuring tasks with distribution boards	61-62
Celsion type fire-resistant distribution boards - possible measurement tasks on distribution boards	63
Storage and environmental conditions / Manufacturer's declaration / Disclaimer	64-65
Service hotline	65

General matters

These assembly and operating instructions are meant for practical use and must be made available to the user/builder at the place where the fireproof system is being used. It does not absolve the builder from its obligation to comply with all the specifics and details on the certificates of suitability and checking the systems immediately after delivery. Keep these assembly and operating instructions inside the fireproof system. It can only be guaranteed that the system will work perfectly if the following instructions and safety-related instructions are followed. A guarantee regarding the IP class is only possible if the unit is set up properly.

You will find the series number on the sticker inside the system.

Safety-related information

- Please note the requirements on the certificates of suitability!
- Please note the building law requirements (esp. in the Federal State Building Order) and building stipulations!
- Please note the instructions in the MLAR, MBO, Technical Building Rules or MVV-TB!
- Please note the extended documentation obligations resulting from the adaptation of the MBO.
- Please note all the instructions in maintenance contracts!
- Please note the instructions on the safety data sheets for building materials!
- Keep the swivel area of the door clear and the door closed at all times!
- Only use the system in a proper condition!
- Please note the instructions from the technical supervisory service!
- The relevant health and safety at work, accident prevention and DIN/VDE regulations must be followed for setup, operating and maintenance work; this is the operator's responsibility!
- Any area that stores hazardous goods (e.g. in the CGS) must be marked appropriately as an explosive area.
- Please note that the suitability of the product and possible additional surveys must be checked within the project during the planning phase. The area where the products are used must be checked by the customer, e.g. according to the permit.

We recommend that the necessary, safety-related checks are performed by our authorised employees.

Any damage and malfunctions caused by improper transport and setup operations (e.g. because of the large weight) can only be reliably prevented by specialist personnel who have been trained and authorised by us.

You must expect impairment of the system's structural stability when the doors are open, if the system has not yet been attached to the structural shell by screws.

Important information: the operator must be informed in writing by the applicant for a general building supervision permit that the fireproof system only meets the requirements for fire resistance if it is kept closed.

Intended purpose

Depending on the system, it is possible to create spatially separate areas from switch panels or electrical installations in neighbouring halls and work rooms with products from Celsion Brandschutzsysteme GmbH, guarantee the functional integrity of safety equipment prescribed in the Federal State Building Order or facilitate the storage of batteries, combustible liquids and inflammable solid substances.

Developer & manufacturer

Celsion Brandschutzsysteme GmbH
Dresdener Str. 51
D-02625 Bautzen, Germany
office@celsion.de | www.celsion.de

Phone: +49 (0) 3591 / 270 78 - 0
Fax: +49 (0) 3591 / 270 78 - 19

Rating plate

Example LW / LS – 30 minutes

		Brandschutzgehäuse - Typenserie: LW / LS		Minuten 30
Brandschutzprüfung bei einer MPA		Hersteller: Celsion Brandschutzsysteme GmbH Radibor (Bautzen) - Germany Schutzart IP 54, Nennspannung 400 V		
Umgebungsbedingungen: Die Temperatur im Raum am _____ Uhr um _____ Uhr betrug _____ °C		Entwickelt auf der Basis der Vorgaben der MLAR 2005 Teil 3.2.2 und 5.1.1/5.2.2 und IEC 60364-5-56 Punkt: Generals. Serie geprüft in Anlehnung an DIN 4102-12-2 und teilweise Teil 11 gemäß Produktunterlagen. Die Oberflächenbeschichtung ist gem. Bauministerkonferenz kleiner 0,5 mm, Basisbrandschutzplatten nicht brennbar. Bitte beachten Sie für den Funktionserhalt die Vorgaben der MLAR 5.1.1 Wechselwirkung z.B. Temperatur und Feuchtigkeit im Gehäuse. Bitte beachten Sie des Weiteren die Bedienungsanleitung.		
Beachtung der Übertemperatur nach VDE 0660 Teil 507 erfolgt		Herstellungsjahr: 20 _____ Typ: _____		
- ja <input type="checkbox"/> / nein <input type="checkbox"/>		Seriennummer: _____		
<small>Stand 03/2015</small>				

The following data is found on the rating plate (on the inside of the cabinet/distribution board door):

- Manufacturer of the fireproof cabinet
- Series number and year of manufacture
- Fireproof class – model series
- Building material class
- Usability / guidelines for testing
- Ambient temperature when setting up the fireproof cabinet

Please note when setting up the fireproof cabinet that the necessary information on the ambient temperature (temperature, time, date, noting any excess temperatures) must be written down on the rating plate by the builder.

Transport

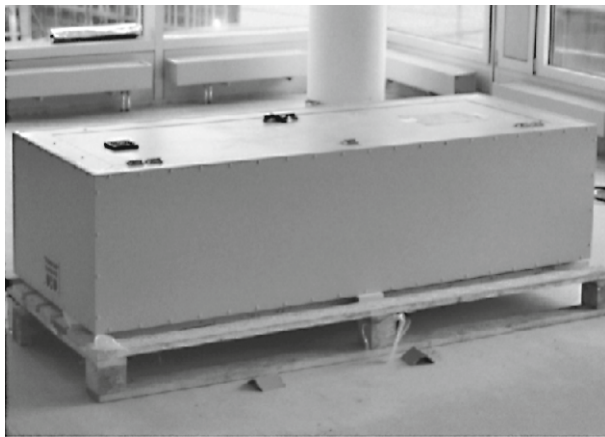

- The fireproof system is supplied on a transport pallet
- The systems must be immediately checked after delivery and any defects that are recognised must be immediately noted on the accompanying document/consignment note with the freight forwarder. Defects must be communicated to the vendor or Celsion Brandschutzsysteme GmbH in writing (at the latest 5 days after delivery). The transfer of risk takes place at delivery. Any defects, which may have occurred by further transporting the systems, are excluded from any rectification.
- Transport the fireproof system to the place of use with a suitable pallet truck on a transport pallet with corner protection and fastening ties.

Any improper transportation (strong impacts, transport without air suspension, repeated reloading, unbalanced load when setting up the unit etc.) may affect the fireproof function (damage to the fireproof panels or their connections).

If the system is to be repositioned, this must be completed smoothly and fully extensive. The system must be closed for this.

General information

Beware, this affects all the fireproof systems:

Any uneven points on the wall surface, that are not touched by the fireproof system, must be evened out with fireproof cement (Crystal-CEL, page 60), if the gap measures more than 4 mm or smoke could emerge in a fire. Walls must be even and vertical. Normal tolerances on walls/plaster must be evened out so that it is possible to assemble the unit so that no smoke or flames escape.

The closure feature for the opening in a fireproof cabinet is simply described as a door in these assembly instructions. Inspection openings are referred to as inspection doors and flaps are also described as doors.

Commissioning fireproof distribution boards

- **The unit may tip over if the doors are open before it has been attached**
- **Align fireproof systems horizontally and vertically for wall assembly**
- **Align door/cover (i.e. not offset in or on the system)**
- **Assemble the system vertically and flush with the wall to prevent any displacement of the gap dimensions in the door area (take note of the cross)**

After aligning the system, please screw it to the structural shell immediately. Please use the frame dowels (only suitable for concrete, full tile bricks, solid lime-sand bricks, porous concrete, perforated bricks and lime-sand perforated bricks), which are supplied for attaching the system (after checking their suitability) or dowels that suit the building material (authorised cavity dowels, porous concrete dowels, injection dowels, plastic dowels etc.) in line with the certificate of suitability. The requirements for dowels at the edges of the solid building materials should be noted too.

Before use, the cabinet should be subjected to a safety-related check. This should primarily involve the correct fit and that all the seals are available (door seal, cable entry point, ventilation system [above and/or below]).

The system is opened using the rotating levers inserted in the door. This should be opened and turned 90° to the right/left (depending on the door hinge) or below or above (Violution series). The locking rods in the door slide back inside the door and the system can be easily opened to the right or left without any great effort (maximum 180°). If there are double doors, the right door leaf (top view) should be opened first and then the left door leaf. Close them in reverse. If they are turned improperly or excessively in the same direction, the locking system may be damaged. When closing the door, please note that the locking rods have moved back into position (rotating lever 90° to the right/left) and the door has been gently pressed into the cabinet. The rotating lever can be easily closed if the door is shut properly. Please note that the hinges will be overstretched if the doors are opened more than 180° and any cracks and damage to the door area caused by this must be checked and eliminated by experienced Celsion employees. When opening the distribution board doors if the unit has been supplied horizontally, the doors must be supported.

The CGS 60 has a self-closing unit. The door locking system or the safety cabinet may be damaged by any improper handling. The self-closing door elements are adjusted in the factory (according to DIN 14470-1). This setting must be retained and not changed (risk of injury/prevents the unit from working properly). This must be checked to see that it works and the settings are correct during any maintenance/inspection (more information: see page 10).

Any dismantling of the screw-fitted door leads to a loss of the warranty. If dismantling cannot be avoided for weight or space reasons, our authorised service employees can dismantle the door and safeguard the fireproof function. This does not apply to the small distribution boards (CV and CK series), where the lid can be removed/opened using the quick-action locks, rotating lever or screws.

The dismantling of the LWA doors is an exception here (LWA-E, LWA-R, LWA-E-R and CWA-R) according to the assembly and operating instructions.

Please note the total power loss of the inserted units and the wiring compared to the specified power loss from the cabinet (VDE 0660). Please note the maximum figures on the current price list.

When attaching the insertion frame or assembly panels in the distribution boards, the Spax screws may not be screwed into the inner wall of the fireproof system more than 18 mm. The screws may only be screwed into the side walls and the rear wall; any screws placed in the door in any project must be clarified first with Celsion.

Functional test, care and maintenance, safety-related check

The systems are viewed as a safety-related unit and need to be maintained at least once a year and its function should be checked. In your interest, we recommend that you conduct a monthly functional test (visual check according to page 61). Please note the specifications in points 4 and 5 of the certificates of suitability.

In the case of fireproof cabinets with ventilation systems, the functionality and operating readiness of the ventilation systems must be available at all times.

Checks should be performed at least twice a year.

In the case of components with a high heat loss, please replace the filter every six months.

Checks on the fireproof systems and maintenance of the ventilation system must be performed by trained Celsion personnel or employees of Celsion Brandschutzsysteme GmbH.



After successfully mounting the fireproof system on the wall, the transport label can be removed as follows:

1. Slowly peel off the sticker at one corner and dispose of it.
2. Remove any remains of glue with turpentine or cleaning fluid.
3. Take note of the maintenance and cleaning information.

Normal, mild household cleaning agents can be used to clean the outside of the system without any hesitation. The outer surfaces have a decorative design.

The closure mechanism on the door does not need to be maintained. Before installing electrical fittings, the system can be cleaned with a damp cloth or rag. The hinges on the door can be lubricated with graphite.

On cabinets with double doors or wall attachment doors with just one rotating lever, please note that the slides inserted on the inside must be released before opening the second door. When closing the door, the slides must be locked again.

Locking mechanisms



Rotating lever and 2-point lock (material: metal)

Rotating lever for DIN profile half cylinder or comparable locking systems. The lock cylinder can be replaced by loosening the attachment screws on the cylinder. It is possible to insert a comparable lock for master key systems by a simple modification.

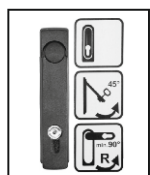

Rotating lever and 2-point lock (material: PA)

Rotating lever for DIN profile half cylinder or comparable locking systems. The lock cylinder can be replaced by loosening the attachment screws on the cylinder. It is possible to insert a comparable lock for master key systems by a simple modification.



Quick-action lock (material: metal)

2 or 4 quick-action locks on opposite sides. Optionally with an eyelet for padlocks.



Self-locking system (see page 10)

Both door elements can be opened or locked independently of each other because there are two door closers. The door elements close automatically in line with the specifications in DIN EN 14470-1.



Cam lock (material: metal)



Cam lock with screw connection (material: metal)



Assembly instructions for free-standing distribution board – wall attachment

(LS / CS / FSE / AV/SV / MAXX / DBV* / CNV / Violution S-30/S-90**)

1. Check that all the accessories are present:

- 2 x fasteners
- 1 x two-way key
- 1 x operating instructions
- 1 x maintenance checklist (see page 61)

2. Take the system to the assembly place on a suitable lifting device e.g. scissors lift.

3. Align the distribution board vertically on the wall and mark the drill holes through the pre-drilled holes on the rear wall. Do not drill through the rear wall – risk of breakage!

- 4. The precise drilling depth depends on the dowel length and should be determined as follows:**
Required drilling depth = dowel length – component thickness + 10 mm
-Minimum anchorage depth of the enclosed dowels: 70 mm;
-Drill diameter: 10 mm

5. Extract the drilling dust, insert the dowels using push-through installation (screw head flush) and tighten the screw with a suitable spanner/screwdriver – do not overtighten! Do not sink the screw head in the material.

6. Place the plastic caps on the attachment anchors and press firmly. (optional)

7. Coat the plastic caps on the attachment anchors with fireproof cement to guarantee the type of protection. (optional)

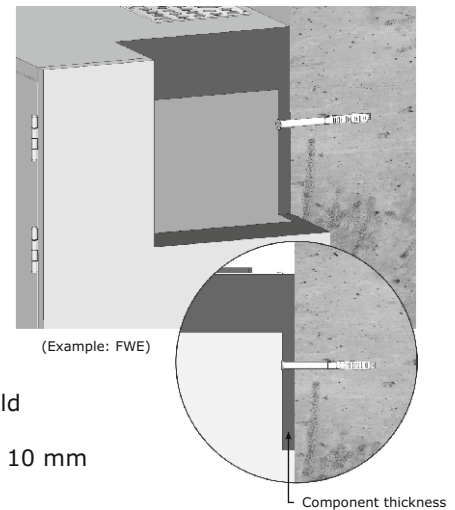

* Note the special features of the product series

** Note the special features - see assembly info for "Setting up the base for Violution 90" p.46/47

Assembly instructions for free-standing distribution board without a base – ground attachment

(LS / CS / FSE / AV/SV / MAXX / DBV* / CNV / Violution S-30)

1. Check that all the accessories are present:

- 4 x fasteners
- 1 x two-way key
- 1 x operating instructions
- 1 x maintenance checklist (see page 61)

2. Place the system at the set assembly height using a suitable lifting device, e.g. scissors lift.

3. Align the distribution board vertically on the wall and mark the drill holes through the pre-drilled holes in the cabinet floor. Do not drill through the floor – risk of breakage!

- 4. The precise drilling depth depends on the dowel length and should be determined as follows:**
Required drilling depth = dowel length – component thickness + 10 mm
-Minimum anchorage depth of the enclosed dowels: 70 mm;
-Drill diameter: 10 mm
Please note: check the drilling area in advance – the project may involve restrictions like underfloor heating, cables etc.

5. Extract the drilling dust, insert the dowels using push-through installation (screw head flush) and tighten the screw with a suitable tool/screwdriver – do not overtighten! Do not sink the screw head in the material.

6. Place the plastic caps on the attachment anchors and press firmly. (optional)

7. Coat the plastic caps on the attachment anchors with fireproof cement to guarantee the type of protection (optional).

* Note the special features of the product series

Alternatively, we can provide you with our assembly videos too! (see page 8)

Assembly instructions for wall distribution board – wall attachment

(LW / CW / FWE / Violution W-30)

1. Check that all the accessories are present:

- 4 x fasteners
- 1 x two-way key
- 1 x operating instructions
- 1 x maintenance checklist (see page 61)

2. Place the system at the set assembly height using a suitable lifting device, e.g. scissors lift.

3. Align the distribution board vertically on the wall and mark the drill holes through the pre-drilled holes on the rear wall. Do not drill through the rear wall – risk of breakage! (Note diagonal measurement)

4. The precise drilling depth depends on the dowel length and should be determined as follows: required drilling depth = dowel length – material thickness + 10 mm
-Minimum anchorage depth of the enclosed dowels: 70 mm;
-Drill diameter: 10 mm

5. Extract the drilling dust, insert the dowels using push-through installation (screw head flush) and tighten the screw with a suitable spanner-screwdriver – do not overtighten! Do not sink the screw head in the material.

6. Place the plastic caps on the attachment anchors and press firmly. (optional)

7. Coat the plastic caps on the attachment anchors with fireproof cement to guarantee the type of protection. (optional)

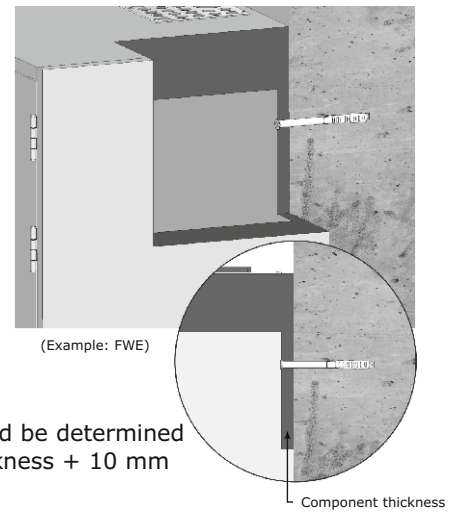

Alternatively, we can provide you with our assembly videos too! (see below)

Assembly video – free-standing/wall distribution boards



Additional assembly video for
assembly and operating
instructions

**Free-standing
distribution board**



Additional assembly video for
assembly and operating
instructions

**Wall
distribution board**

Assembly instructions for wall distribution boards – wall attachment (Violation W-90)

1 Check that all the accessories are present:

What is delivered:

Wall attachment set
Two-way key
Setup and operating instructions
Cable boxe(s)

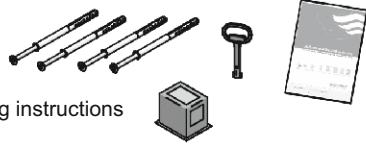

Tools required:

Spirit level, cordless screwdriver, drill with suitable drill bit (Ø 10 mm)

Necessary visual and functional checks directly after delivery:

Are the flexible seals round the cabinet closure mechanism in a perfect state?

Do the rotating levers close and lock?

Is the rating plate/production sticker present?

Please note that the fireproof resistance of the Violution series can only be guaranteed if the cabinet is kept within the state prescribed in the certificate of suitability at all times.

2 Set up the main structure so that it is stable

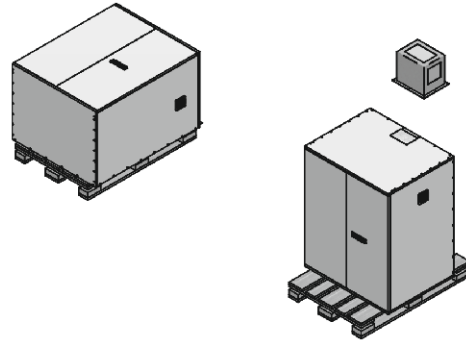

3 Position the fireproof cabinet

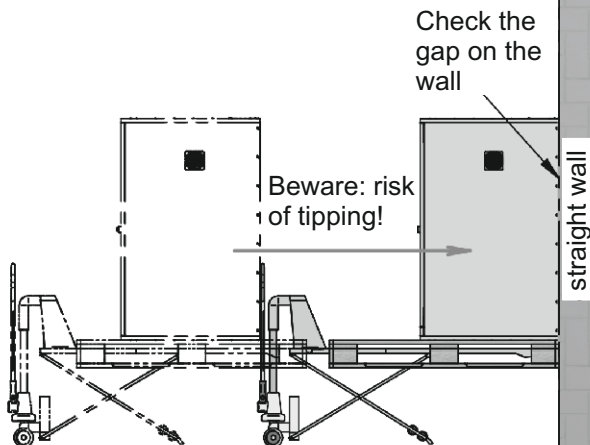

4 Prevent tipping: drill the attachment drill hole through the rear wall of the cabinet into the

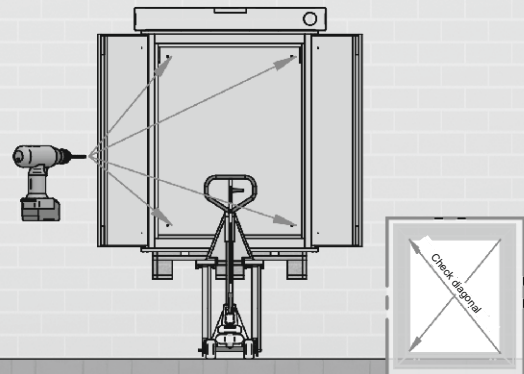

5 Attach the fireproof cabinet to the wall

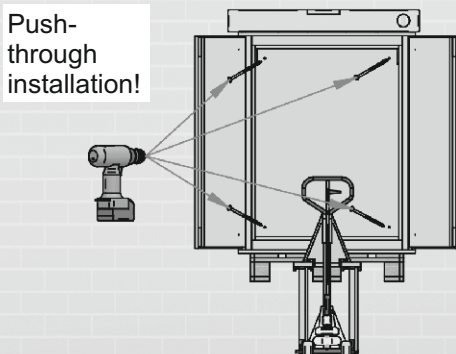

6 Assemble the cable box

See separate assembly instructions for "Violation 90 – cable box"...

Assembly instructions

Safety cabinet type CGS 60*

1. Check that all the accessories are present:

- 1 x operating instructions
- 1 x maintenance checklist (see page 61)

2. Take the system to the setup point with a suitable lifting device.

(A unit can be placed under the base; dismantle the cover and then assemble it again.)

* Note the special features of the product series

Technical data

(CGS 60)

- Total load: Per shelf 70 kg extensive - max. 280 kg
- Other features:
- Single container: max. volume: 36,34 l (total volume: 400 l)
 - Floor tray volume: 39,98 dm³
 - Dual KLS ventilation system (d = 100 mm)
 - Connection for feed and extraction air installation in line with labelling
 - Six-monthly checks on seals and foamer
 - Opening angle approx. 90°

The pressure loss measured with a 10-fold change of air is about < 5 Pa (in the cabinet) and < 10 Pa (in line with EK5 AK4 09-10).

Keep closed if not in use. Only authorised personnel are allowed to open the hazard cabinet.

Procedure after exposure to fire:

- May only be opened after a period of 6 times the length of the fire (using a spark-free tool)
- An inflammable steam/air mixture may have formed, depending on the length of the fire
- > Sources of ignition within a radius of 10 m must be removed

Please note: Check the proper connection of the ventilation system with an extraction system using suitable aids like small smoke pipes. If no compulsory ventilation is connected, the direct environment has a potentially explosive atmosphere and the relevant marking must be made on the cabinet.

The floor tray may not be used as a storage area.

A declaration of conformity can be requested from the manufacturer. Other technical data on request.

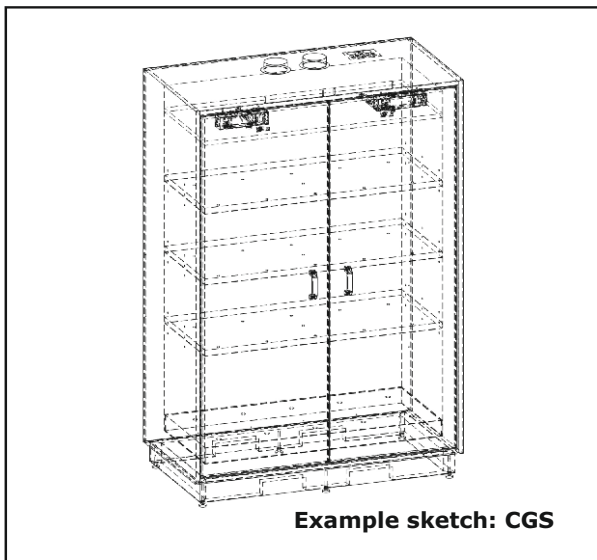

You can find the latest certificates of suitability at www.celsion.de/downloads or on request.

Assembly instructions for wall attachment – wall attachment door

(LWA)

1 Check that all the accessories are present

What is delivered:
Wall attachment set
Two-way key(s)
Operating instructions

a.) Dowel 10 x 135 mm
b.) Dowel 10 x 240 mm
with certificate of suitability / general building supervision permit (abZ)

Tools required:
Hammer
Spirit level
Pallet truck
Pliers
Cordless screwdriver with Torx T40
Punch (Ø 2-3 mm)
Masonry drill (Ø 10 mm)

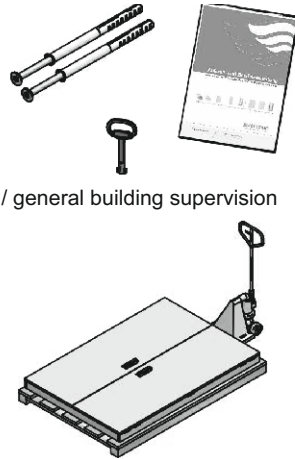

2 Separate the halves of the hinges

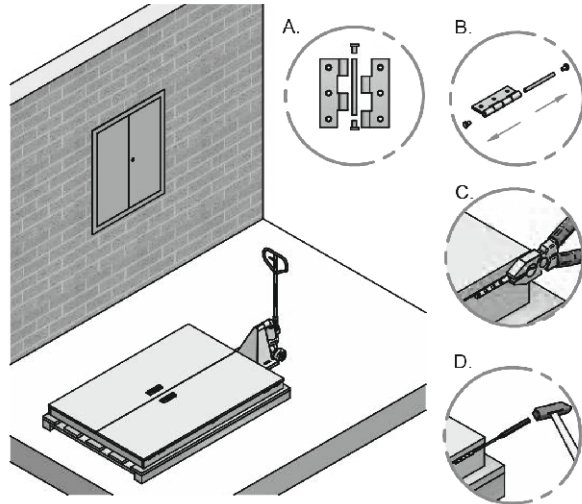

3 Remove the cabinet closure mechanisms

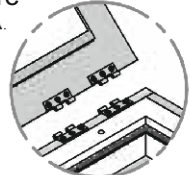
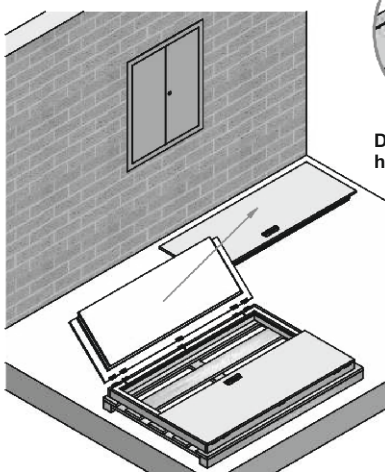

Do not unscrew the halves of the hinges!

Beware: the cabinet closure mechanisms must be stored horizontally in a flat area with the inside facing downwards!

4 Straighten, position and align frame vertically and horizontally

Important: check the diagonal measurement!
Beware: risk of breakage!

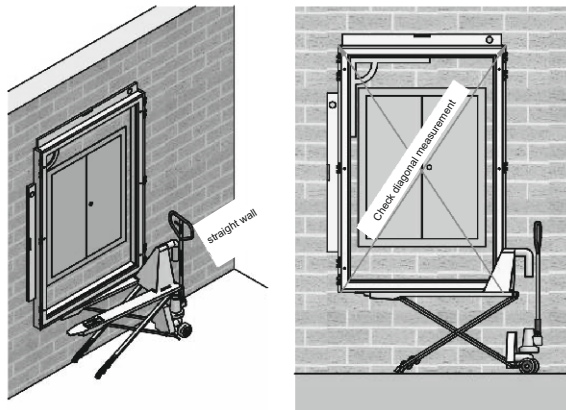

5 Carefully drill through the upper pre-drilled holes (right/left) in the frame

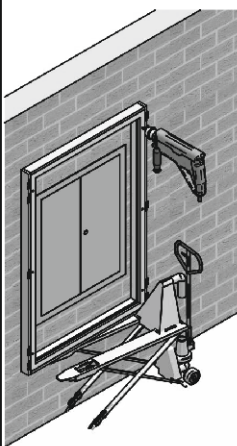

Drill holes
Beware: risk of breakage!
Extract the drilling dust



Watch out for any cables under the plaster!

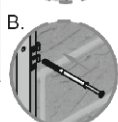

Insert the envisaged dowels (dowel sleeve and dowel screw) in the pre-drilled holes in the frame.

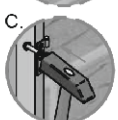

Lightly tap the dowel screw with a hammer until the dowel sleeve is flush with the frame

6 Fix the LWA frame to the wall



Do not overtighten the dowel screws, as overtightening can damage the frame (risk of breakage)

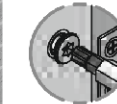

Torx T40

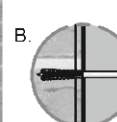

Fixed to the wall by 2 dowels (right/left) at the top of the frame

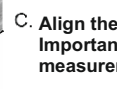

Align the frame at the bottom. Important: check the diagonal measurement!

Assembly instructions for wall attachment – wall attachment door

(LWA)

7 Carefully drill through the lower pre-drilled holes in the frame

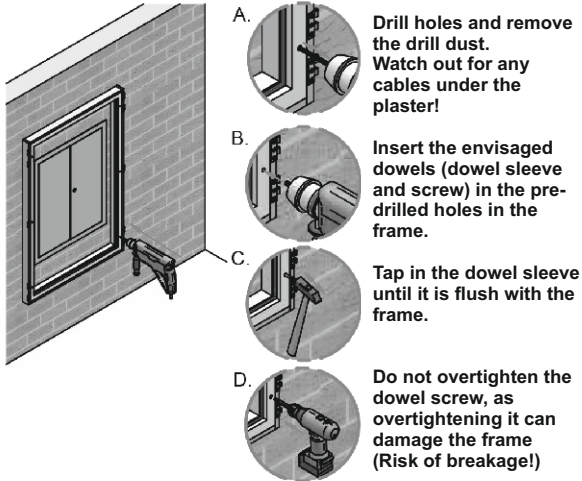

8 Carefully drill through the remaining pre-drilled holes in the frame. (Use the working stages in section 7)

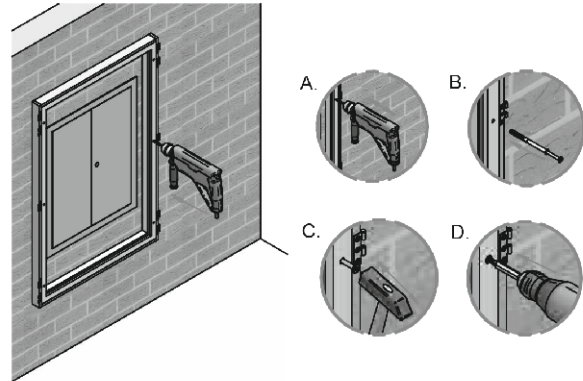

9 Insert the cabinet closure mechanism (left) (working stages in the reverse order of 2 + 3)

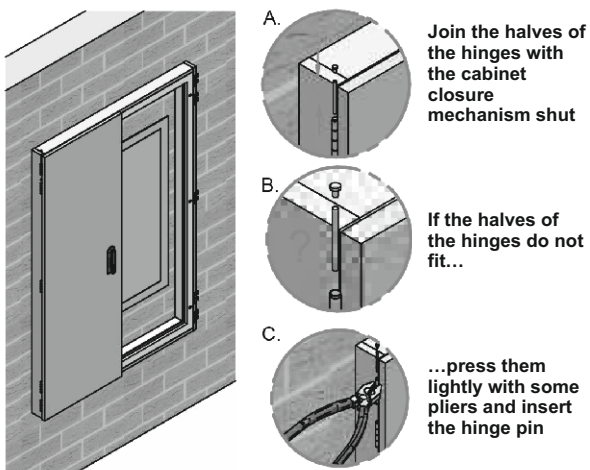

10 Insert the cabinet closure mechanism (right)

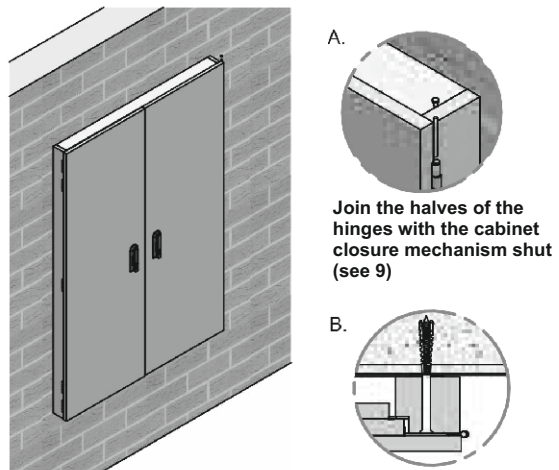

11 Check that the cabinet closure mechanisms move easily

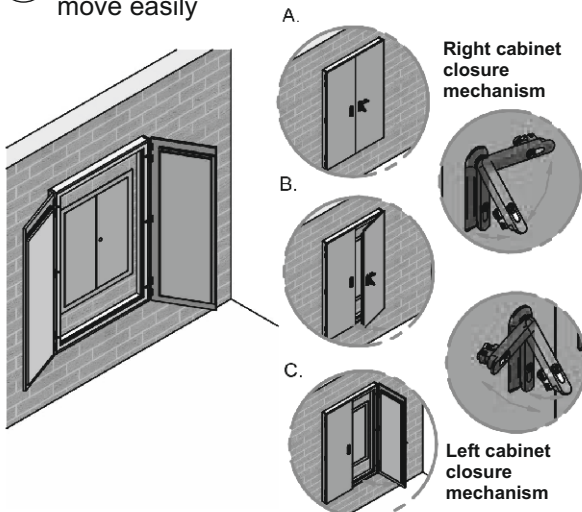

12 Final check

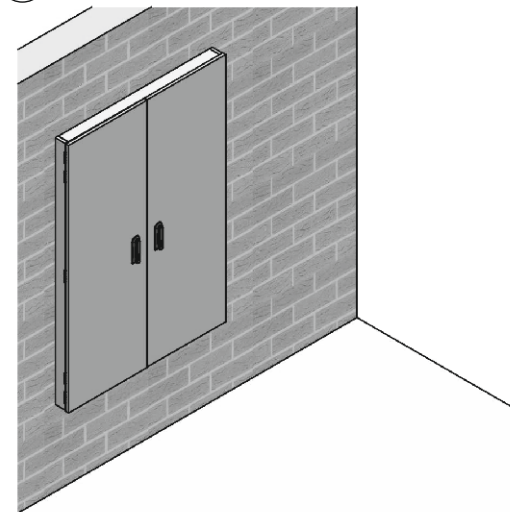

Assembly instructions for wall attachment – wall add-on enclosure (LWÜ / LWÜ-E)

1 Check that all the accessories are present

What is delivered:

Wall attachment set
Two-way key(s)
Operating instructions
Injection mortar

Tools required:

Hammer
Spirit level
Pallet truck
Pliers
Masonry drill (Ø 16 mm)
Allen key
Bolt (Ø 2-3 mm)
Cordless screwdriver

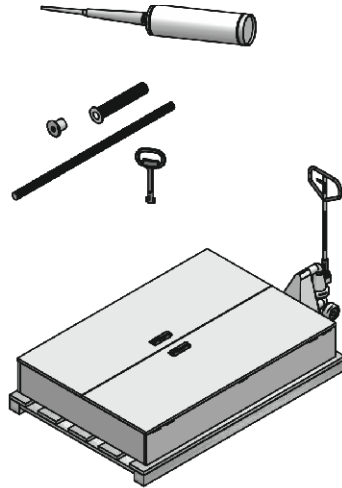

2 Separate the halves of the hinges

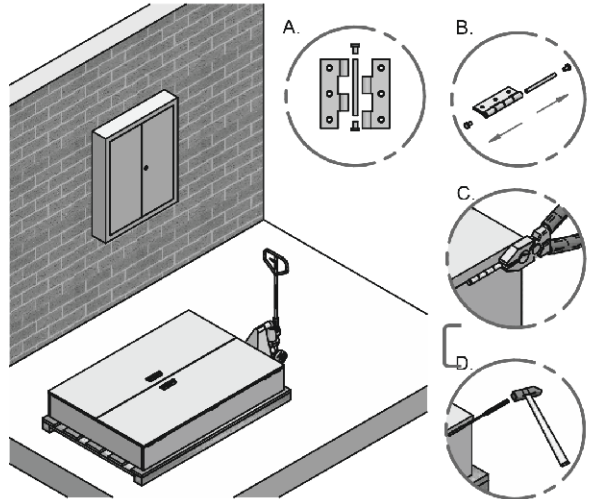

3 Remove the cabinet closure mechanisms

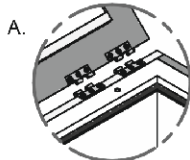
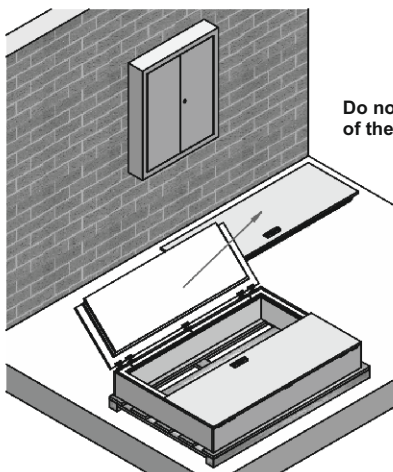

Do not unscrew the halves of the hinges!

Beware: the cabinet closure mechanisms must be stored horizontally in a flat area with the inside facing downwards!

4 Straighten, position and align frame vertically and horizontally

Important: check the diagonal measurement!
Beware: risk of breakage!

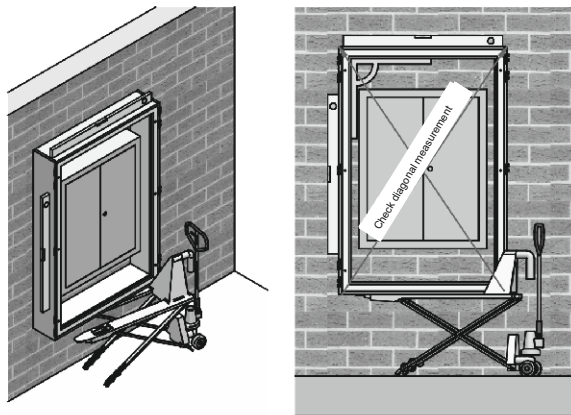

5 Transfer the measurements of the attachment holes to the wall

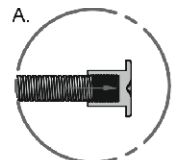
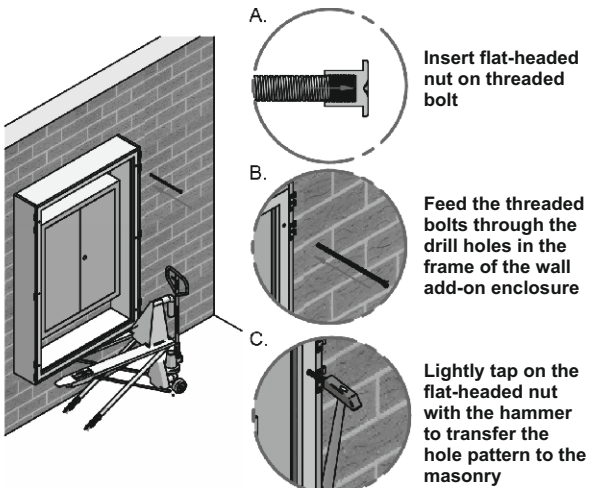

Insert flat-headed nut on threaded bolt

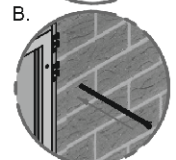

Feed the threaded bolts through the drill holes in the frame of the wall add-on enclosure

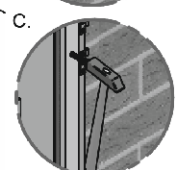

Lightly tap on the flat-headed nut with the hammer to transfer the hole pattern to the masonry

6 Remove the LWÜ unit from the wall again Drill holes for plastic anchor sleeves

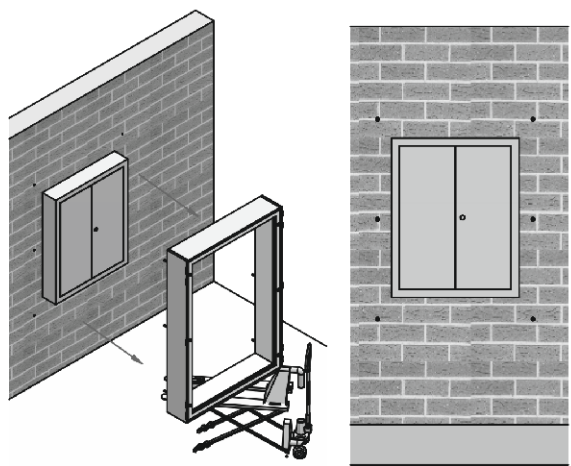

Assembly instructions for wall attachment – wall add-on enclosure

(LWÜ / LWÜ-E)

7 Drill the pre-marked holes in the wall of the building

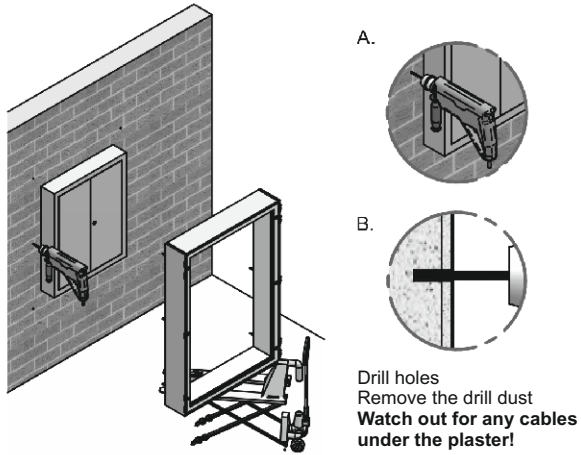

8 Insert the anchor sleeves

Please note: quick work is necessary
Note the operating instructions for the injection mortar

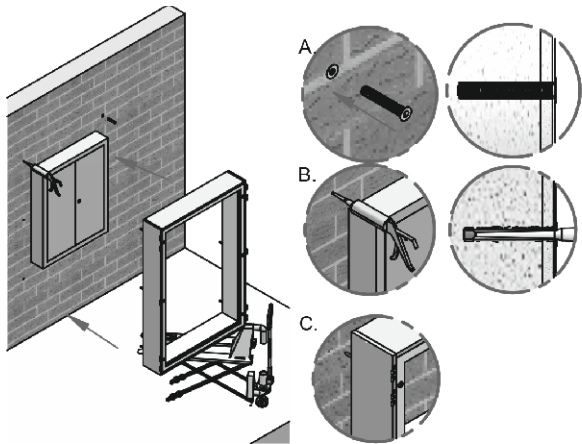

9 Push the wall add-on enclosure on to the building wall with the threaded bolts
Place the anchor bolts in the anchor sleeves
Please note: quick work is necessary!

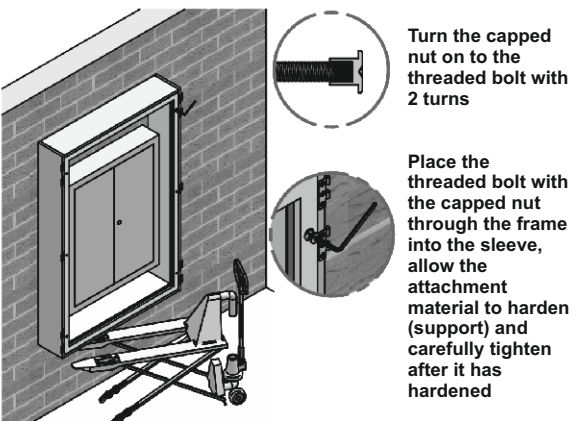

10 Insert the cabinet closure mechanism (left)
(working stages in reverse order to 2 + 3)

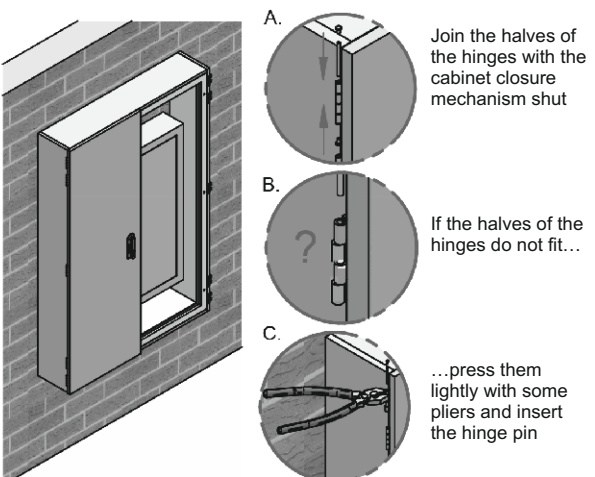

11 Insert the cabinet closure mechanism

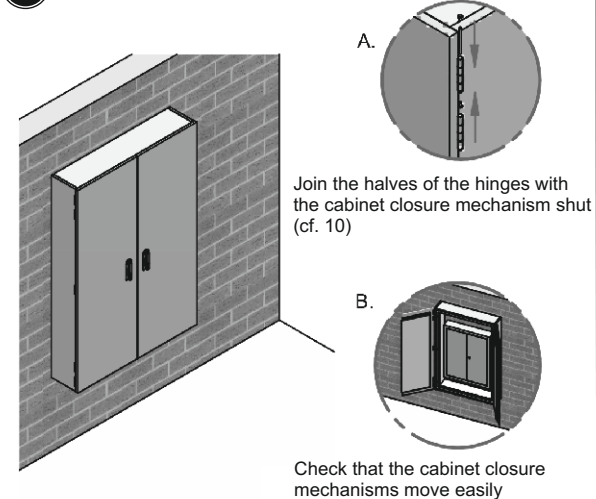

12 Final check

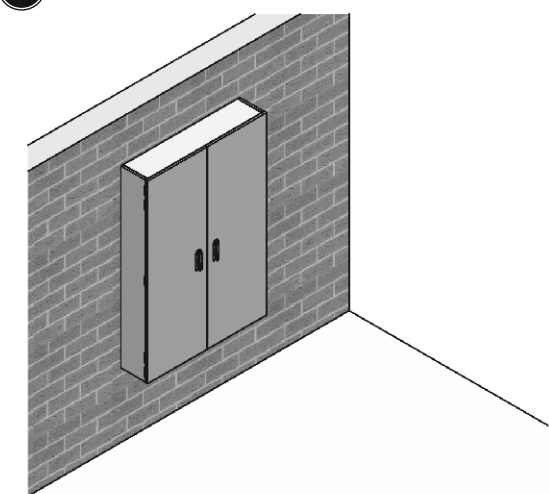

Additional assembly information

for the LWA / LWÜ series

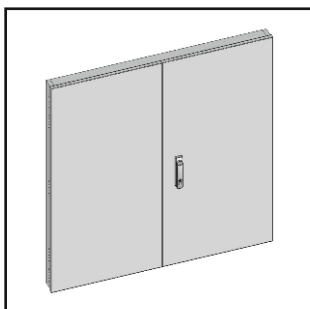

1. Release the LWA unit that is supplied from the transport pallet at the assembly point. Any damage must be mentioned on the delivery note. Later transport damage after the unit has been assembled may not be recognised by the transport insurance company.
2. The doors must be loosened from the frame before assembly on the wall. Carefully remove the hinge caps with some pliers. Remove the hinge pin carefully with a thin screwdriver or drill.

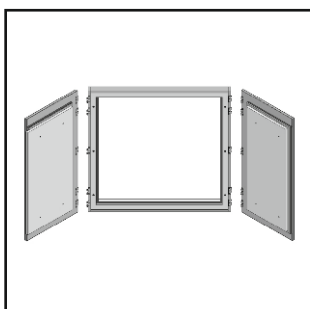
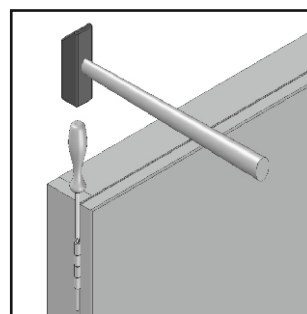
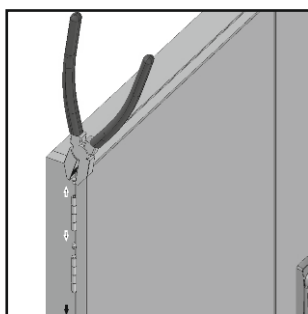
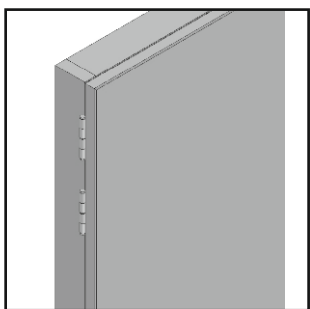

3. Loosen the doors and hinges from the frame and store carefully. Larger LWA/LWÜ wall add-on enclosures are already split up when delivered. Please start with paragraph 4.

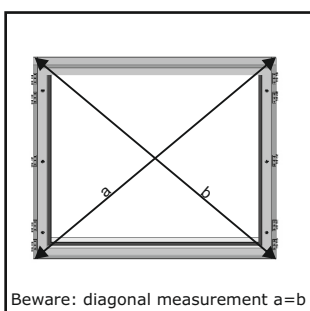

Beware: diagonal measurement $a=b$

4. Align the wall frame on the niche needing to be covered. Attach flush to the wall using the enclosed dowels, after making the drill holes.

Beware: do not use the frame of the wall add-on door as the drilling pattern. Only mark the drill holes and do not drill through the frame.

Risk of breakage! Then drill the holes previously marked in the building's wall. The frame must not be bent, otherwise there is a risk that it will not be possible to repair the gaps of the door and its alignment later.

Check the diagonal measurement before assembling.

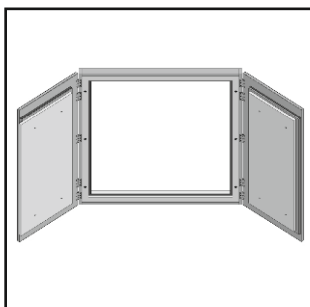

Put the doors back in the frame and insert the hinge pin. Then press the hinge caps firmly into the hinges.

Please check that the hinge caps fit properly.

It takes about 30 minutes for expert, trained employees to assembly a standard door (~1000 x 1000 x 60 mm).

Additional assembly information

for the LWA / LWÜ series with dowels or threaded bolts

1. Attachment through dowels that are supplied

Beware: please check that the dowel can be used with the wall.

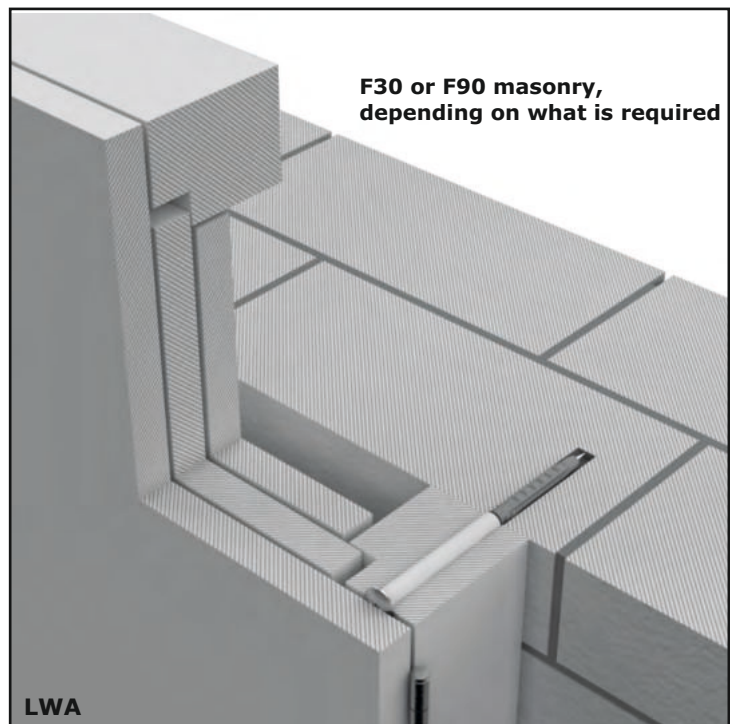

2. Attachment through supplied injection dowels.
The attachment bolt must be flush with the frame on the wall add-on door, as the doors can no longer be closed otherwise.

!! Leave enough space so that you can tighten the cap nut with a spanner or a ratchet **!!**

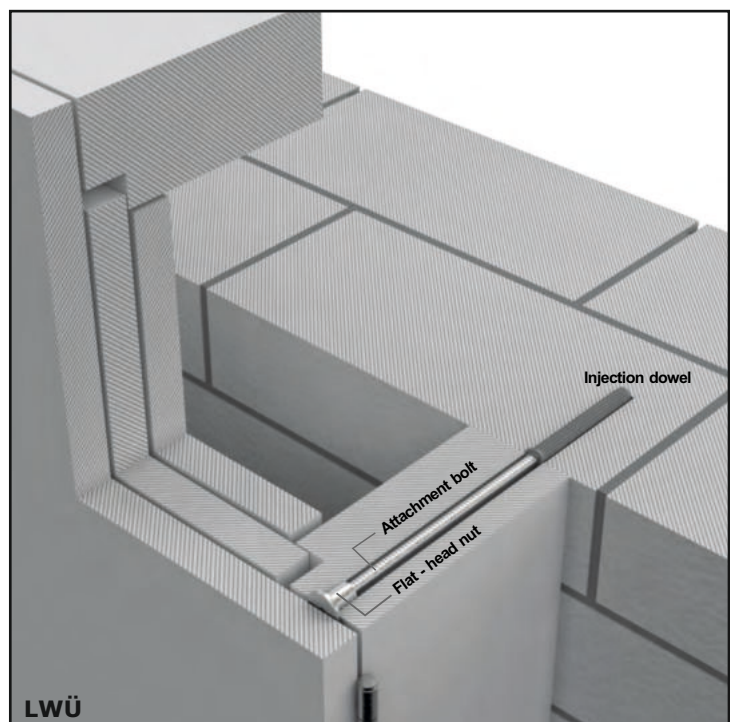

The gap measurements on large doors may not be straight because of the weight of the door. Tolerances of a few millimetres are approved and do not impair the fireproof function. This can be avoided by checking the diagonal measurements and vertically aligning the frame.

Assembly instructions for wall attachment – wall attachment door (LWA-E)

1 Check that all the accessories are present

What is delivered:

Wall attachment set
Two-way key(s)
Operating instructions
Fireproof cement
a.) FUR 10 x 135 mm
b.) FUR 10 x 230 mm
with certificate of suitability /
general building supervision
permit (ABZ)

Tools required:

Hammer
Spirit level
Pallet truck
Pliers
Cordless screwdriver with Torx
T40
Punch (∅ 2-3 mm)
Masonry drill (∅ 10 mm)
if drill holes exist in the frame
Carbide drill (HSS ∅ 10 mm)

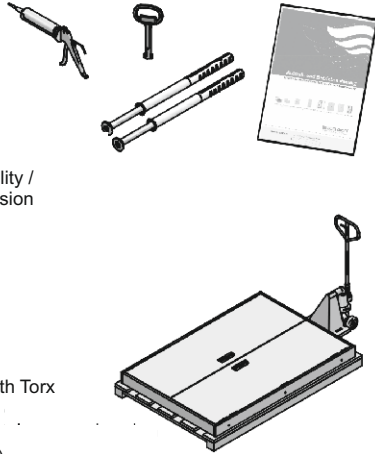

2 Separate the halves of the hinges

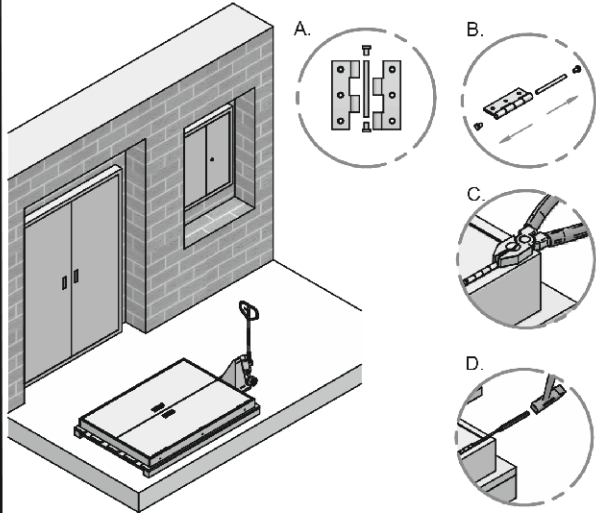

3 Remove the cabinet closure mechanisms from the frame

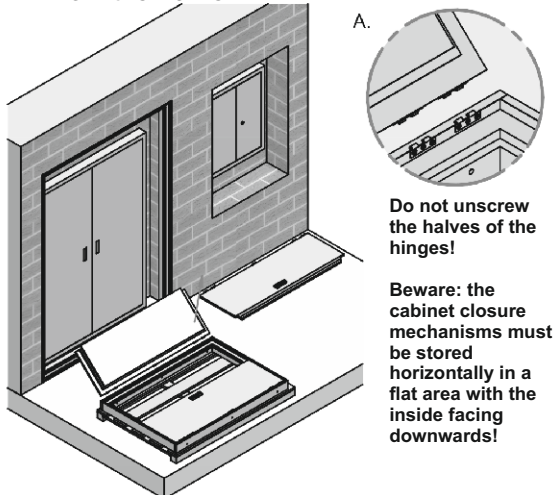

4 Straighten and position the frame and align it vertically and horizontally

Important: check the diagonal measurements!
Beware: risk of breakage!

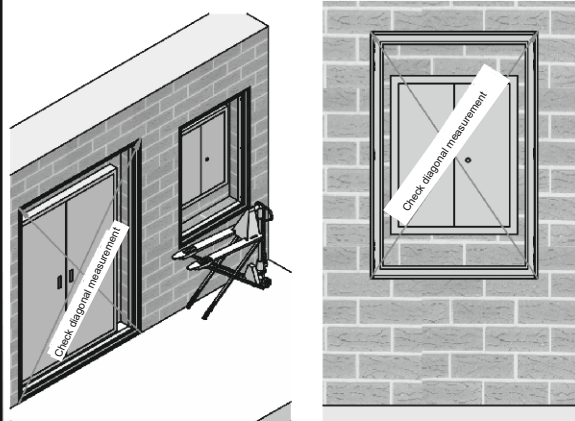

5 Carefully drill through in the upper part of the frame (right/left)

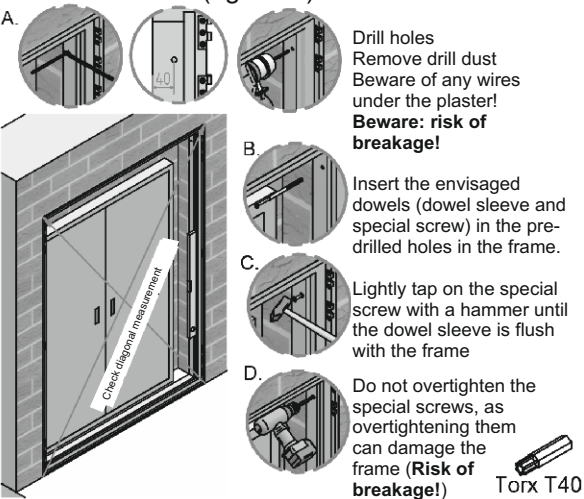

6 Carefully drill through the upper pre-drilled holes (right/left) in the frame

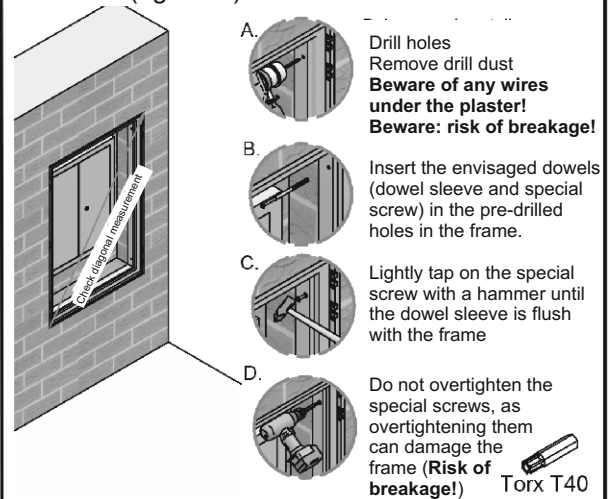

Assembly instructions for wall attachment – wall attachment door

(LWA-E)

7 Carefully drill through the lower pre-drilled holes (right/left) in the frame

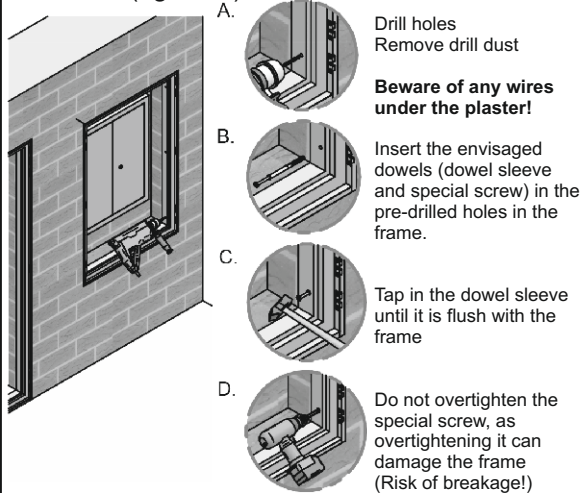

8 Carefully drill through the remaining pre-drilled holes in the frame (work stages as specified in 7)

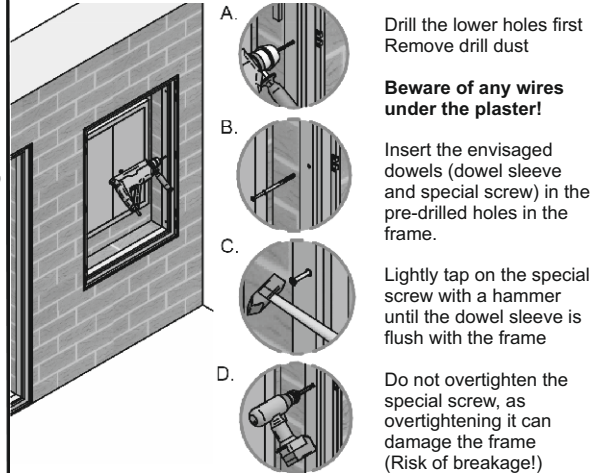

9 Insert the cabinet closure mechanism (left) (work stages in reverse order of 2 + 3)

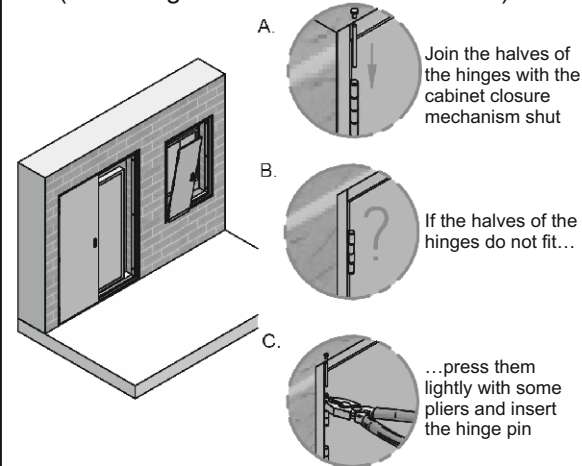

10 Insert the cabinet closure mechanism (right)

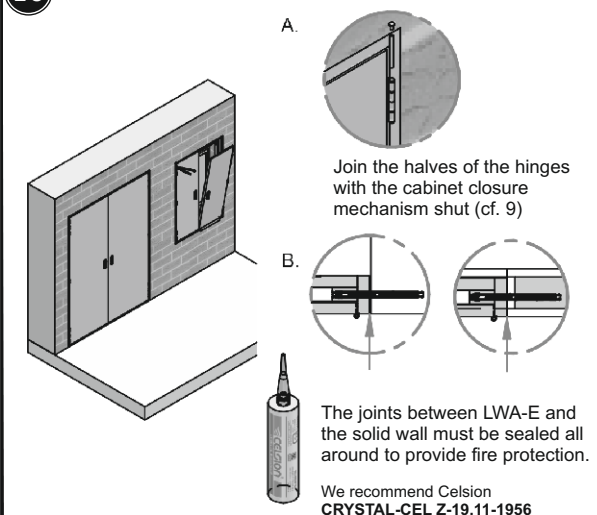

11 Check that the cabinet closure mechanisms move easily

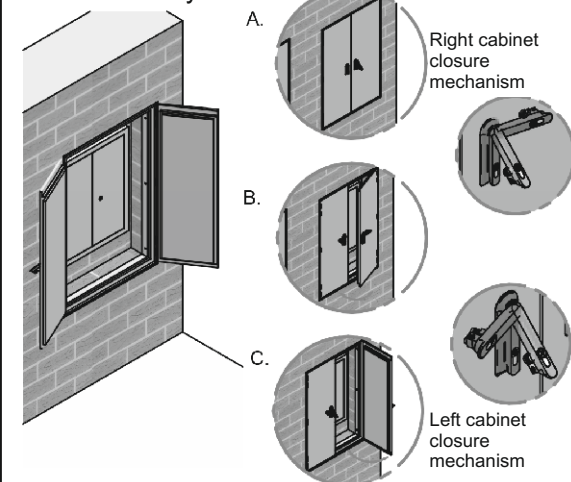

12 Final check

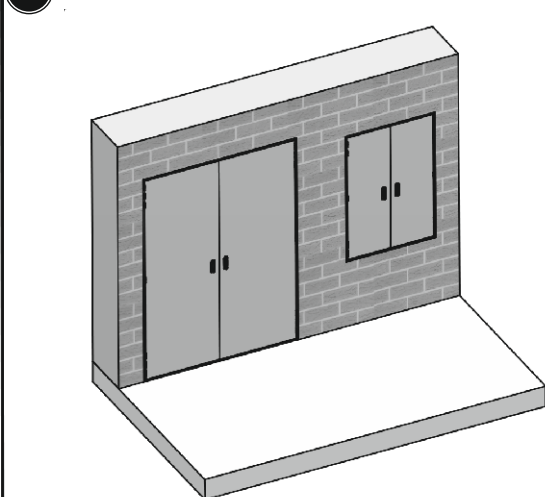

Assembly instructions for wall attachment – wall fitting door

(LWA-E)

1 Check that all the accessories are present

What is delivered:

Wall attachment set
Two-way key(s)
Operating instructions
Fireproof cement

a.) FUR 10x135 mm
b.) FUR 10x230 mm
with certificate of suitability /
general building supervision
permit (ABZ)

Tools required:

Hammer
Spirit level
Pallet truck
Pliers
Cordless screwdriver with Torx
T40
Punch (∅ 2-3 mm)
Masonry drill (∅ 10 mm)
if drill holes exist in the frame
Carbide drill (HSS ∅ 10 mm)

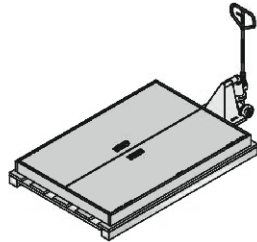

2 Separate the halves of the hinges

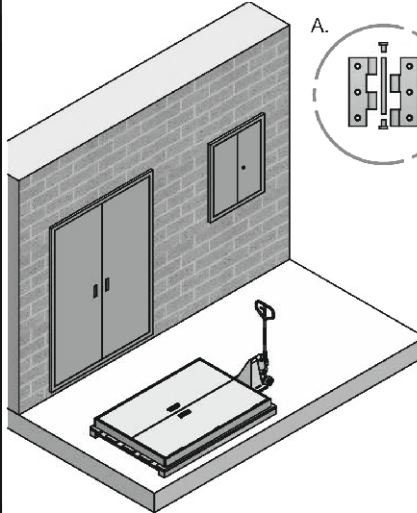

3 Remove the cabinet closure mechanisms from the frame

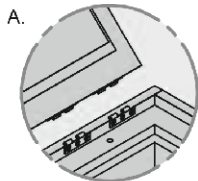
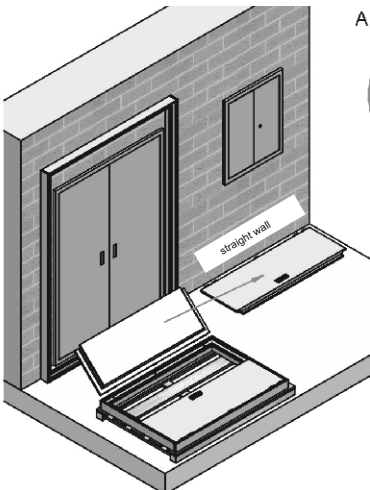

Do not unscrew
the halves of the
hinges!

Beware: the
cabinet closure
mechanisms must
be stored
horizontally in a
flat area with the
inside facing
downwards!

4 Straighten and position the frame and align it vertically and horizontally

Important: check the diagonal measurements!
Beware: risk of breakage!

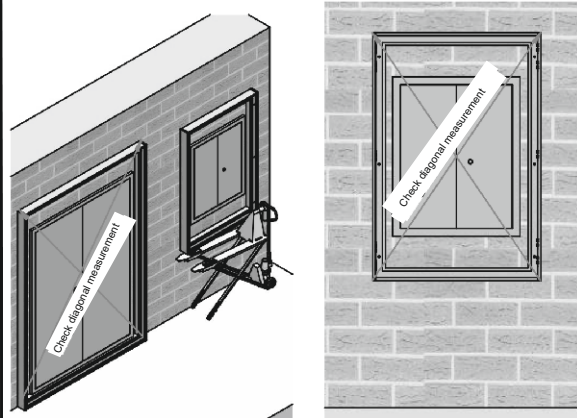

5 Carefully drill through in the upper part of the frame (right/left)

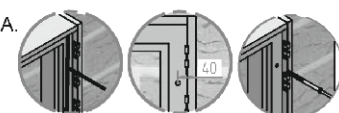

Drill holes
Remove drill dust
Beware of any wires
under the plaster!
**Beware: risk of
breakage!**

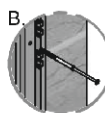

Insert the envisaged
dowels (dowel sleeve and
special screw) in the
pre-drilled holes in the frame.

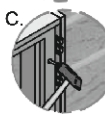

Lightly tap on the special
screw with a hammer until
the dowel sleeve is flush
with the frame

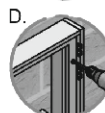

Do not overtighten the
special screws, as
overtightening them
can damage the
frame (**Risk of
breakage!**)



6 Carefully drill through the upper pre-drilled holes (right/left) in the frame

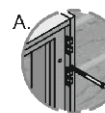

Drill holes
Remove drill dust
Beware of any wires
under the plaster!
**Beware: risk of
breakage!**

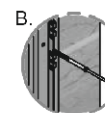

Insert the envisaged
dowels (dowel sleeve and
special screw) in the
pre-drilled holes in the frame.

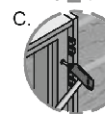

Lightly tap on the special
screw with a hammer until
the dowel sleeve is flush
with the frame

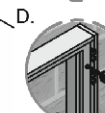

Do not overtighten the
special screws, as
overtightening them
can damage the
frame (**Risk of
breakage!**)



Assembly instructions for wall attachment – wall fitting door

(LWA-E)

7 Carefully drill through the lower pre-drilled holes (right/left) in the frame

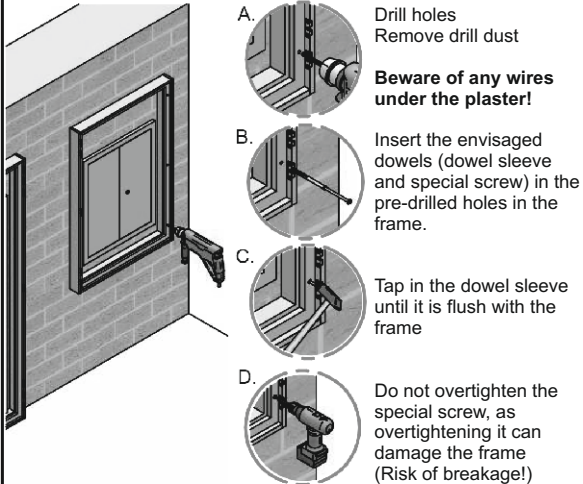

8 Carefully drill through the remaining pre-drilled holes in the frame

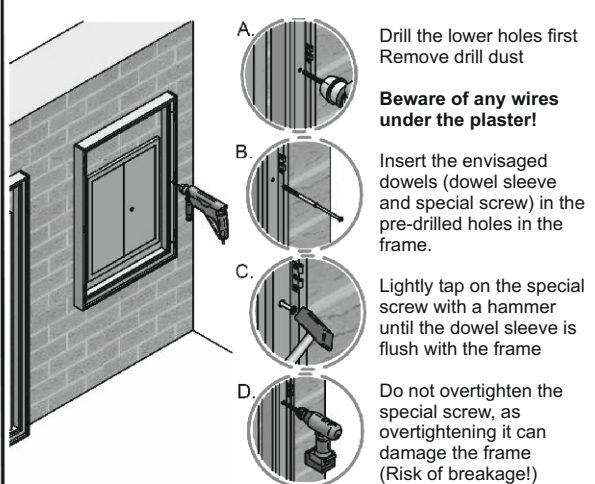

9 Insert the cabinet closure mechanism (left) (work stages in reverse order of 2 + 3)

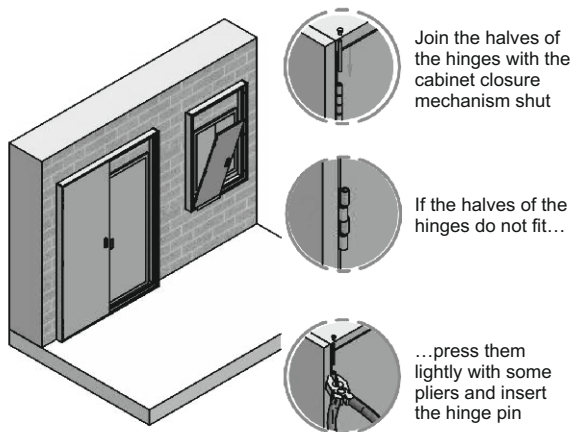

10 Insert the cabinet closure mechanism (right)

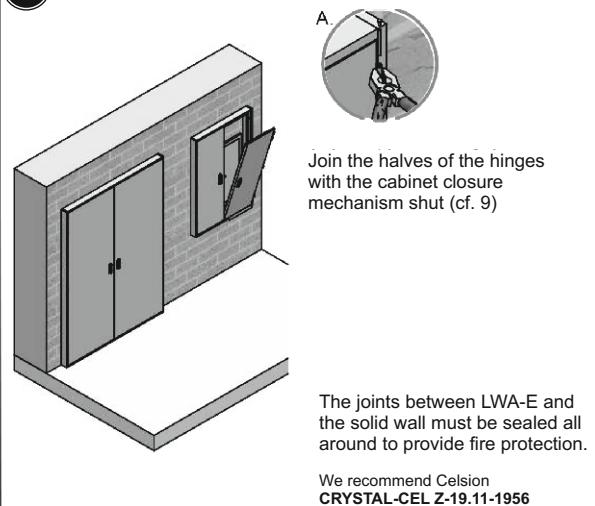

11 Insert the cabinet closure mechanism (left)

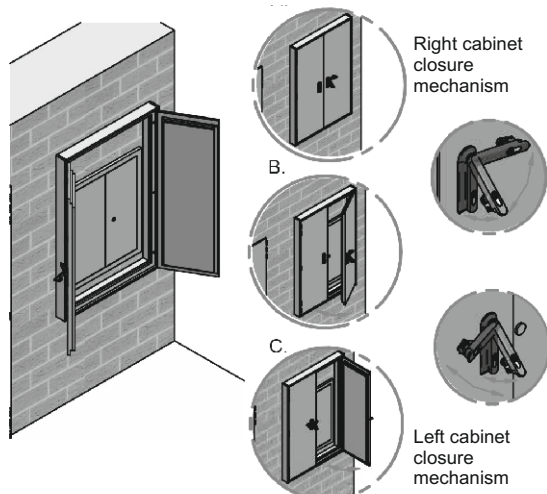

12 Final check

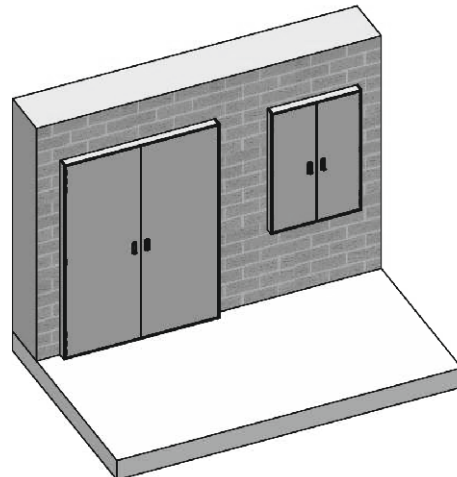

Assembly instructions for wall attachment - inspection doors (VIOPARUM 90) recessed option

1 Check that all the accessories are present

What is delivered:

- 1 x wall attachment set
- 1 – 2 two-way key(s)
- 1 x setup and assembly instructions
- 1 x cartridge of fireproof cement



2 persons required

Tools required:

Spirit level, cordless screwdriver, drill with suitable bit, support to prevent the unit from tipping over

Visual and functional checks required directly after delivery:

- Are the flexible seals round the cabinet closure mechanism in a perfect state?
- Is the frame correctly assembled? Is the cabinet closure mechanism firmly attached to the frame?
- Do the rotating levers close and lock?
- Is the rating plate/production sticker attached?

Please note that the fire resistance capability of the Vioparum 90 is only guaranteed if the Vioparum 90 is always maintained in the condition prescribed in the certificate of suitability.

2 Assemble solid* shaft wall

If it already exists, please check it

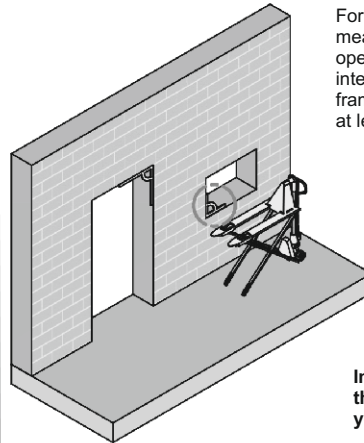

For both design options, the measurements for the opening in the wall reflect the internal measurements for the frame on the Vioparum 90 + at least 5 mm around.

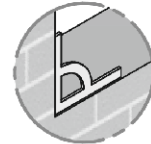

Important: when creating the opening, ensure that you have a 90° angle!

*Not a lightweight dry wall!

3 Straighten and position the frame and align it vertically and horizontally

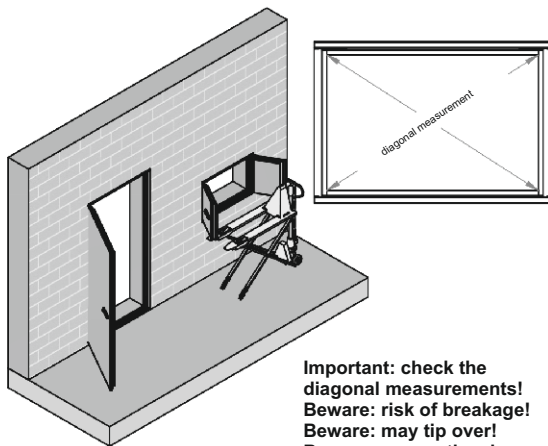

Important: check the diagonal measurements!
Beware: risk of breakage!
Beware: may tip over!
Beware: secure the closure mechanisms!

4 Prepare the attachment drill holes in the solid wall

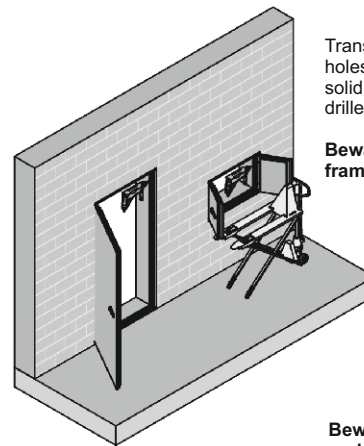

Transfer the attachment drill holes (average 10 mm) in the solid wall through the pre-drilled holes in the frame.

Beware: do not drill into the frame!

Beware: risk of breaking and tipping over!

5 Insert dowel, attach the frame to the solid wall

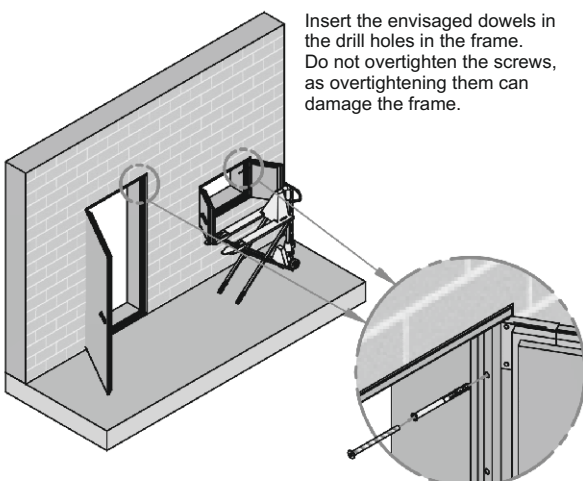

Insert the envisaged dowels in the drill holes in the frame. Do not overtighten the screws, as overtightening them can damage the frame.

6 Seal the joints

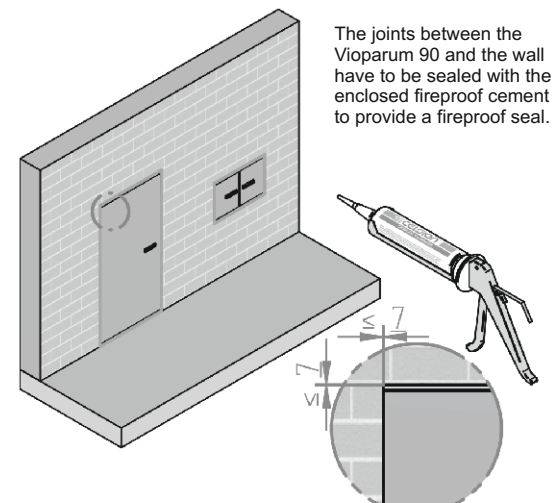

The joints between the Vioparum 90 and the wall have to be sealed with the enclosed fireproof cement to provide a fireproof seal.

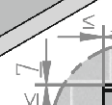

Assembly instructions for wall attachment - inspection doors (VIOPARUM 90) recessed option

7 Check that the cabinet closure mechanisms work easily

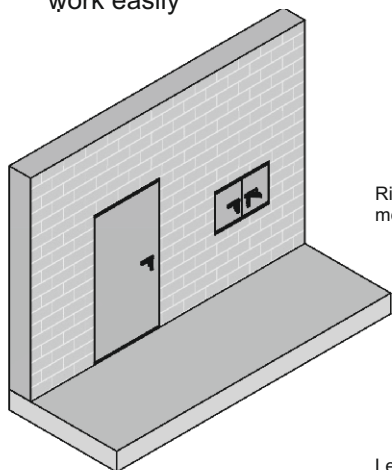

Right cabinet closure mechanism

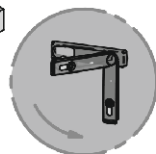

Left cabinet closure mechanism

8 Final check

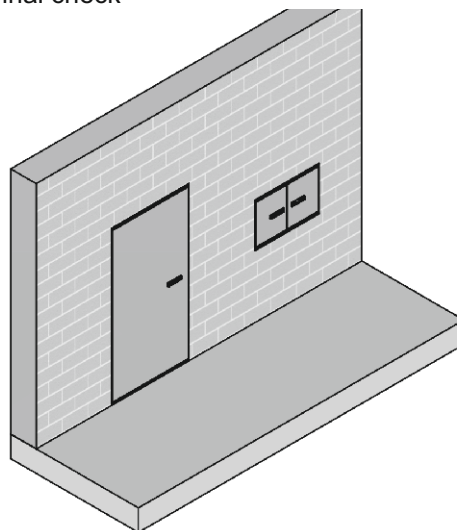

Assembly instructions for wall attachment - inspection doors (CWA-R) add-on option

1 Check that all the accessories are present

What is delivered:

1 wall attachment set with metal frame dowels,
(e.g. 10x172 mm)

Two-way key(s)

1 x assembly instructions

1 cartridge of fireproof cement

Tools required:

Hammer, spirit level, pallet truck, cordless screwdriver, drill with suitable bit (10 mm)

Visual and functional checks required directly after delivery:

Are the flexible seals round the cabinet closure mechanism in a perfect state?

Is the frame correctly assembled? Is the cabinet closure mechanism firmly attached to the frame?

Do the rotating levers close and lock?

Is the rating plate/production sticker attached?

Please note that the fire resistance capability of the CWA-R 30 is only guaranteed if the CWA-R 30 is always maintained in the condition prescribed in the certificate of suitability.

2 Description of the separating wall according to DIN 4102-4

In the case of both option designs, the measurements for the opening in the separating wall match the interior measurements of the frame in the CWA-R 30.

Please also note!

The height of the opening in the separating wall matches the interior measurement + 103 mm for the free-standing design option.

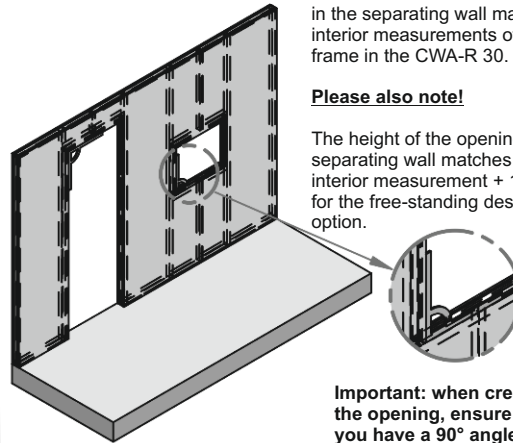

Important: when creating the opening, ensure that you have a 90° angle!

3 Separate the hinge from the frame

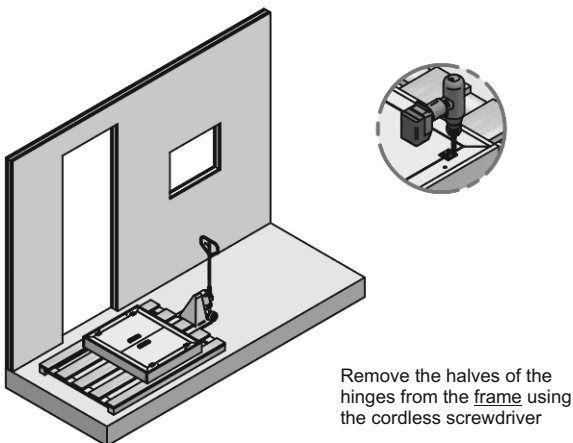

Remove the halves of the hinges from the frame using the cordless screwdriver

4 Remove the cabinet closure mechanisms from the frame

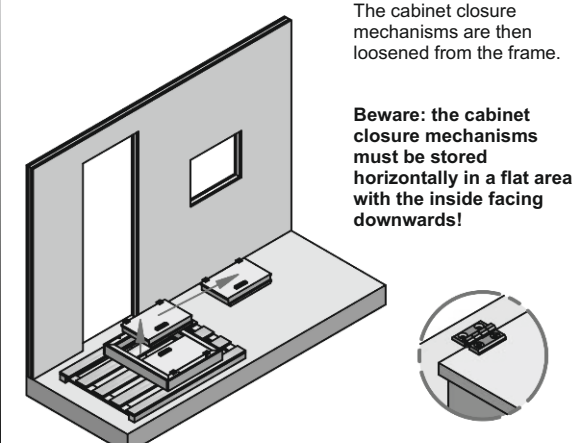

The cabinet closure mechanisms are then loosened from the frame.

Beware: the cabinet closure mechanisms must be stored horizontally in a flat area with the inside facing downwards!

5 Straighten and position the frame and align it vertically and horizontally

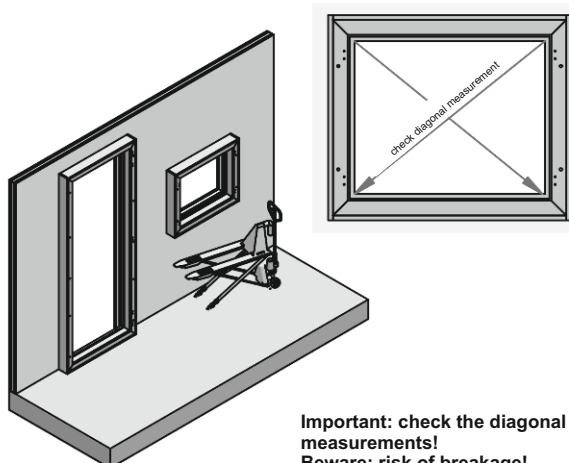

**Important: check the diagonal measurements!
Beware: risk of breakage!**

6 Prepare the attachment drill holes in the stud frame

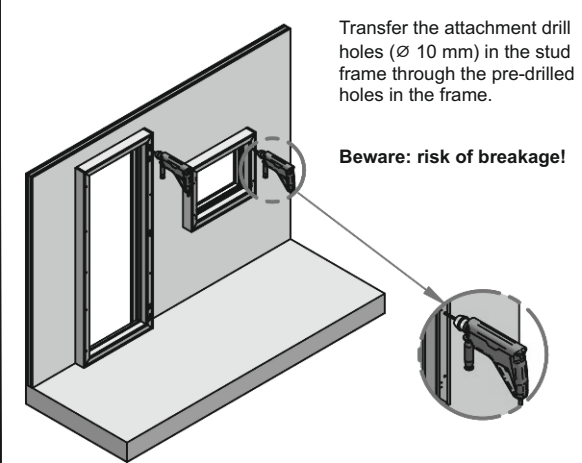

Transfer the attachment drill holes (Ø 10 mm) in the stud frame through the pre-drilled holes in the frame.

Beware: risk of breakage!

Assembly instructions for wall attachment - inspection doors (CWA-R) add-on option

- 7** Insert the metal frame dowels
Attach the frame in the separating wall

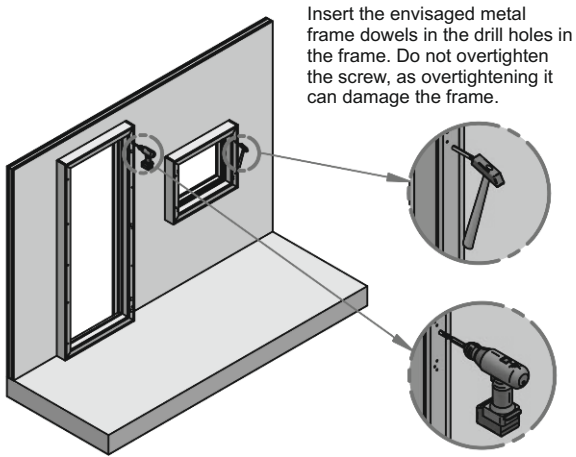

- 8** Insert the cabinet closure mechanism panel (left)

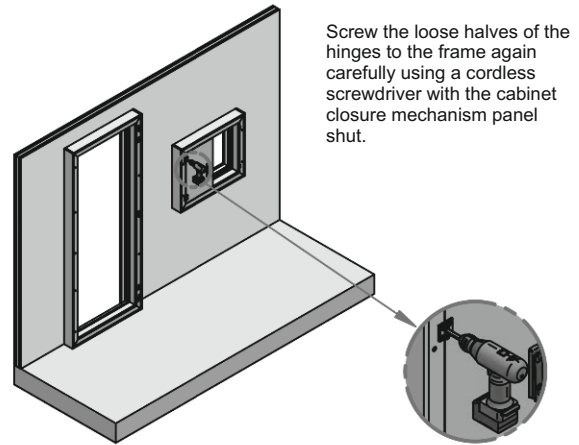

- 9** Insert the cabinet closure mechanism panel (right)

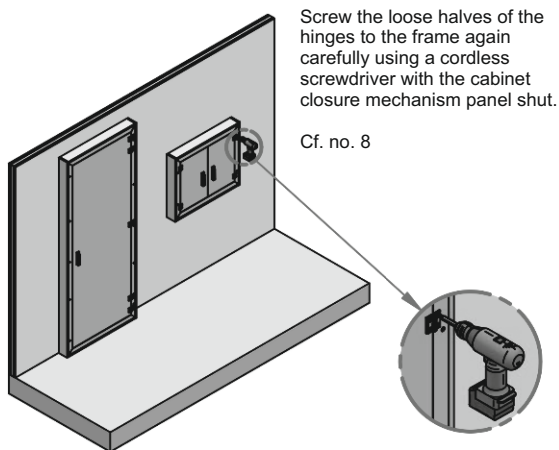

- 10** Seal the joints

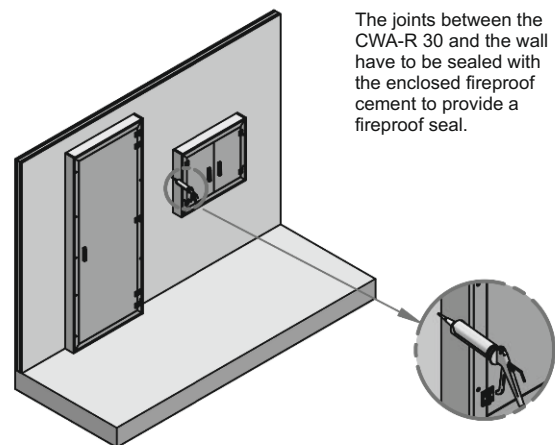

- 11** Check that the cabinet closure mechanisms work easily

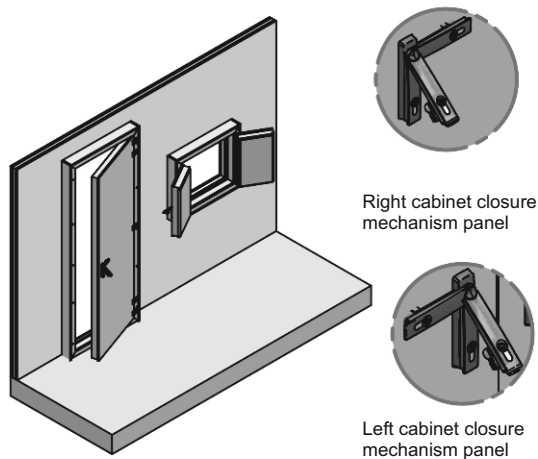

- 12** Final check

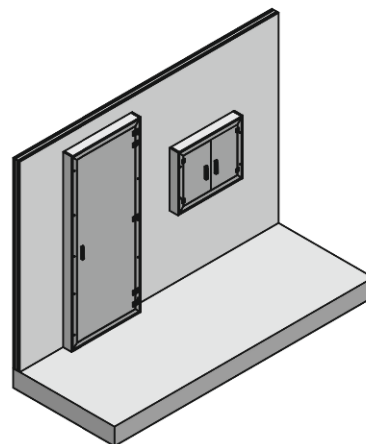

Assembly instructions for wall attachment - inspection doors (CWA-R) recessed option

1 Check that all the accessories are present

What is delivered:

- 1 wall attachment set with metal frame dowels, (e.g. 10x172 mm)
- Two-way key
- 1 x assembly instructions
- 1 cartridge of fireproof cement

Tools required:

- Hammer, spirit level, pallet truck, cordless screwdriver, drill with suitable bit (10 mm)

Visual and functional checks required directly after delivery:
Are the flexible seals round the cabinet closure mechanism in a perfect state?

Is the frame correctly assembled? Is the cabinet closure mechanism firmly attached to the frame?

Do the rotating levers close and lock?

Is the rating plate/production sticker attached?

Please note that the fire resistance capability of the CWA-R 30 is only guaranteed if the CWA-R 30 is always maintained in the condition prescribed in the certificate of suitability.

2 Description of the separating wall according to DIN 4102-4

The measurements for the opening in the separating wall match the outer measurements of the frame in the CWA-R 30.

Important: when creating the opening, ensure that you have a 90° angle!

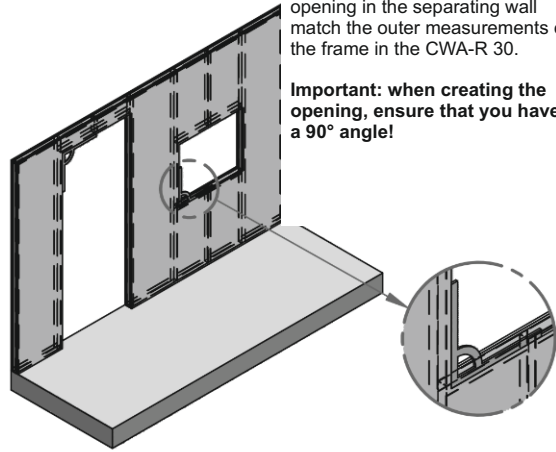

3 Separate the hinge from the frame

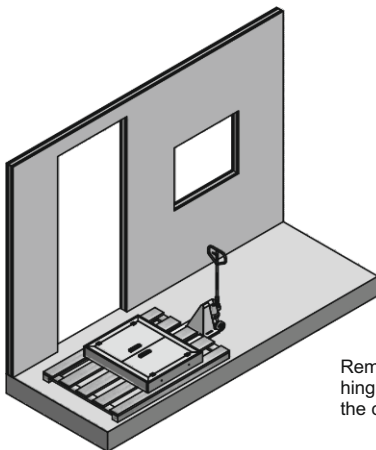

Remove the halves of the hinges from the frame using the cordless screwdriver

4 Remove the cabinet closure mechanisms from the frame

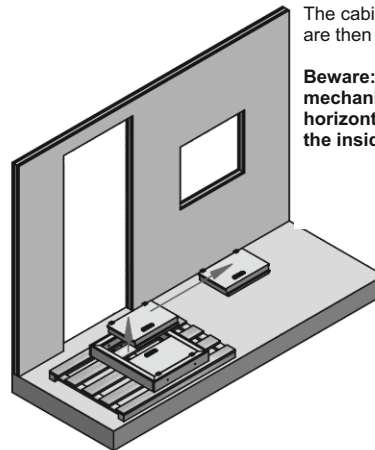

The cabinet closure mechanisms are then loosened from the frame.

Beware: the cabinet closure mechanisms must be stored horizontally in a flat area with the inside facing downwards!

5 Straighten and position the frame and align it vertically and horizontally

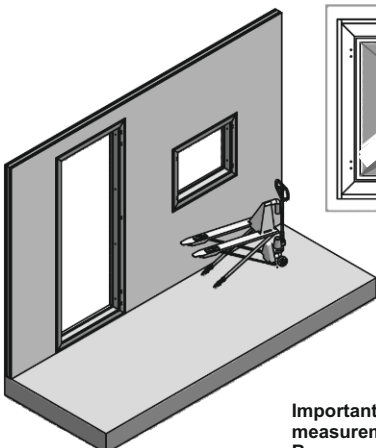

**Important: check the diagonal measurements!
Beware: risk of breakage!**

6 Prepare the attachment drill holes in the stud frame

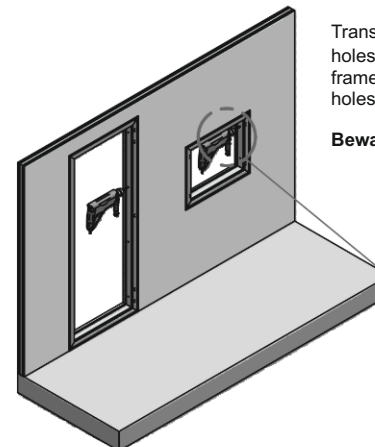

Transfer the attachment drill holes (Ø 10 mm) in the stud frame through the pre-drilled holes in the frame.

Beware: risk of breakage!

Attachment may only take place in the stud frame

Assembly instructions for wall attachment - inspection doors (CWA-R) recessed option

- 7** Insert the metal frame dowels
Attach the frame in the separating wall

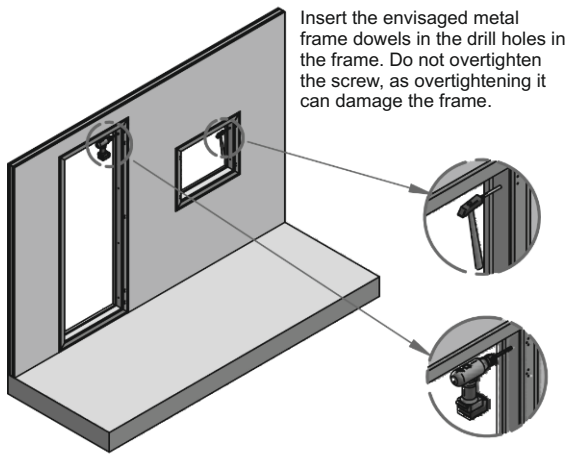

- 8** Insert the cabinet closure mechanism panel (left)

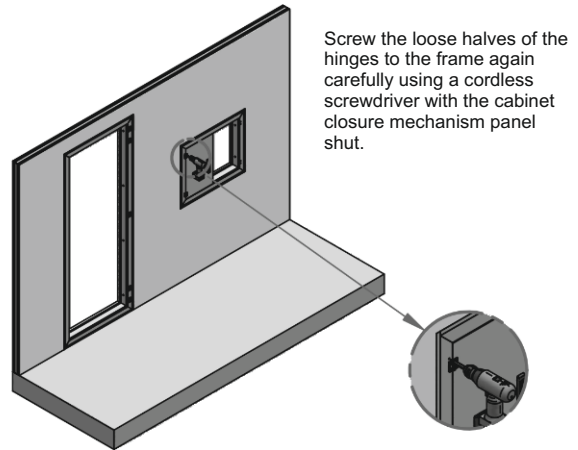

- 9** Insert the cabinet closure mechanism panel (right)

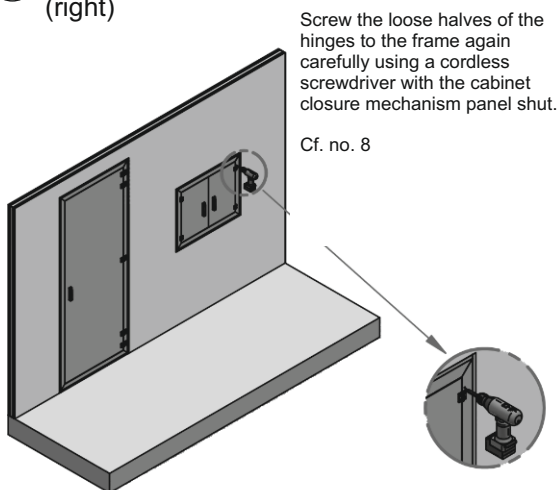

- 10** Seal the joints

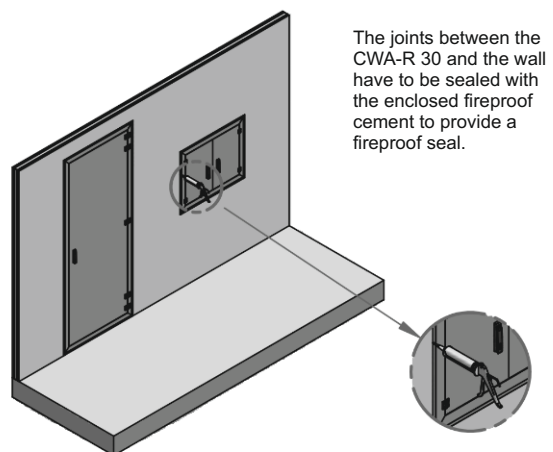

- 11** Check that the cabinet closure mechanisms work easily

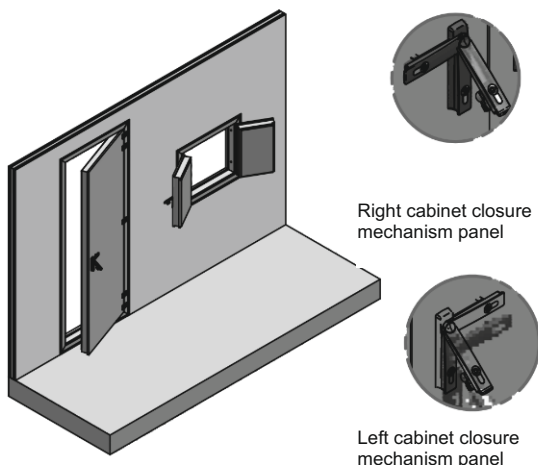

- 12** Final check

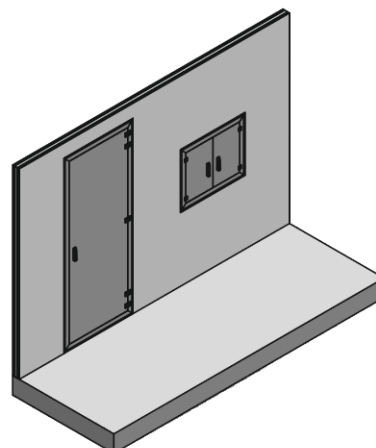

Assembly instructions for wall attachment - inspection doors (LWA-R) add-on option

1 Check that all the accessories are present

What is delivered:

Suitable wall attachment set for installation shafts, according to the static requirements

Two-way key

1 x assembly instructions

1 x cartridge of fireproof cement

Tools required:

Hammer, spirit level, pallet truck, pliers, cordless

screwdriver, bolt (\varnothing 2-3 mm), drill with suitable bit

Visual and functional checks required directly after delivery:

Are the flexible seals round the cabinet closure mechanism in a perfect state?

Is the frame correctly assembled? Is the cabinet closure mechanism firmly attached to the frame?

Do the rotating levers close and lock?

Is the rating plate/production sticker attached?

Please note that the fire resistance capability of the LWA-R 30 is only guaranteed if the LWA-R 30 is always maintained in the condition prescribed in the certificate of suitability.

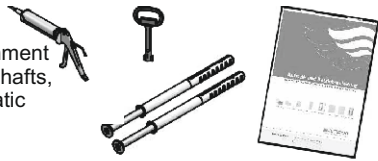

2 Description of the separating wall according to DIN 4102-4

The measurements for the opening in the separating wall match the inner measurements of the frame in the LWA-R 30.

Please also note!

For the free-standing option, the height of the opening in the separating wall matches the inner measurement + 97 mm.

Important: please ensure that you have a 90° angle!

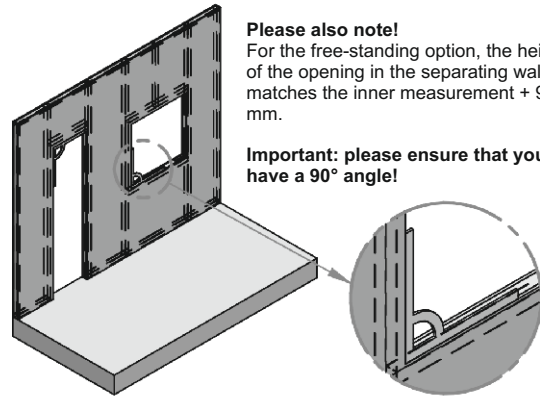

3 Separate the halves of the hinges

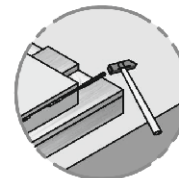
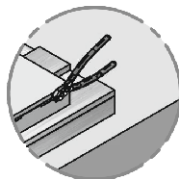
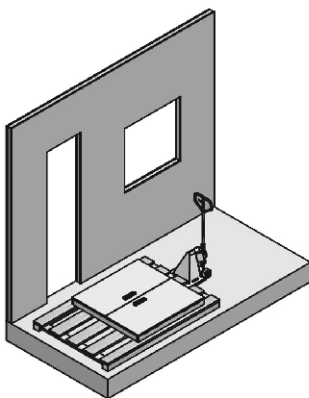

Remove the pin cap with the pliers.
The pin between the halves of the hinges is knocked out using the bolt

4 Remove the cabinet closure mechanisms from the frame

The cabinet closure mechanisms are then loosened from the frame. Do not unscrew the halves of the hinges!

Beware: the cabinet closure mechanisms must be stored horizontally in a flat area with the inside facing downwards!

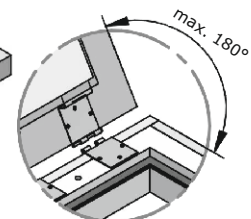
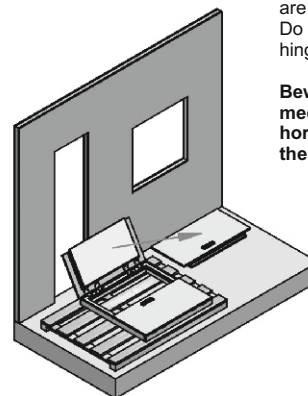

5 Straighten and position the frame and align it vertically and horizontally

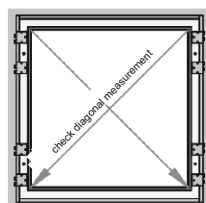
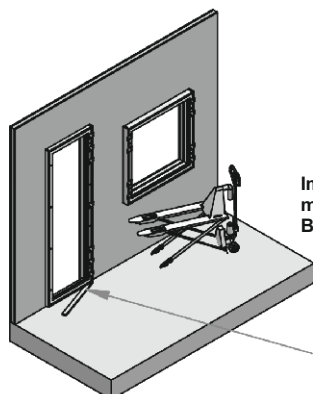

Important: check the diagonal measurements!
Beware: risk of breakage!

An additional fireproof panel (18 mm) is attached between the frame and the solid floor on the free-standing option

6 Prepare the attachment drill holes in the stud frame

Transfer the attachment drill holes (\varnothing 10 mm) in the stud frame through the pre-drilled holes in the frame.

Beware: risk of breakage!

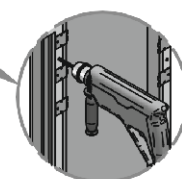
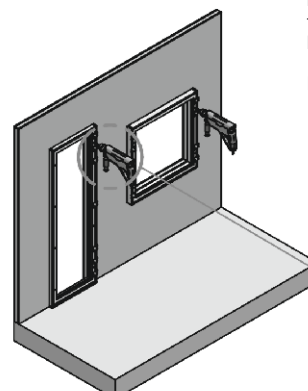

Assembly instructions for wall attachment - inspection doors (LWA-R) add-on option

7 Insert the metal frame dowels Attach the frame to the separating wall

Insert the envisaged metal frame dowels in the drill holes in the frame. Do not overtighten the screw, as overtightening it can damage the frame.

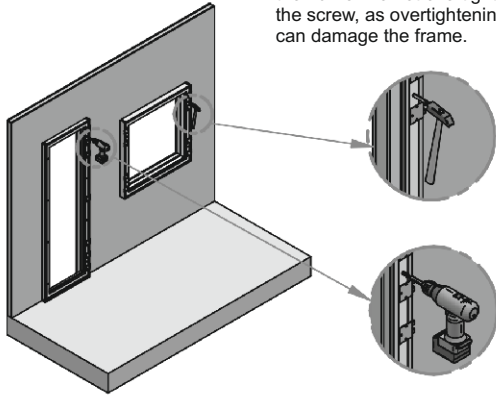

8 Insert the cabinet closure mechanism panel (left)

Join the halves of the hinges with the cabinet closure mechanism panel shut – if the halves of the hinges do not fit, press them lightly together with the pliers and insert the hinge pin. Place the pin cap on again and connect firmly with a small hammer.

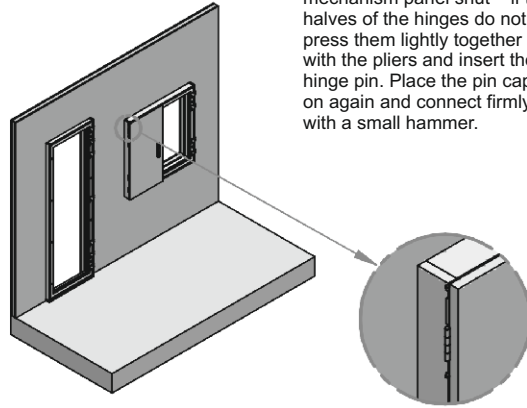

9 Insert the cabinet closure mechanism panel (right)

Attach the halves of the hinges again with the cabinet closure mechanism panel shut.

Cf. no. 8

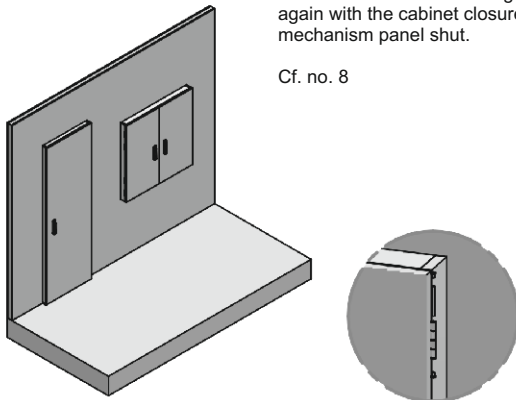

10 Seal the joints

The joints between the LWA-R and the wall have to be sealed with the enclosed fireproof cement to provide a fireproof seal.

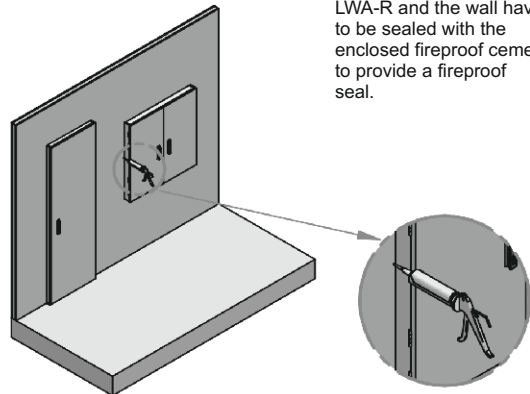

11 Check that the cabinet closure mechanisms work easily



Right cabinet closure mechanism panel



Left cabinet closure mechanism panel

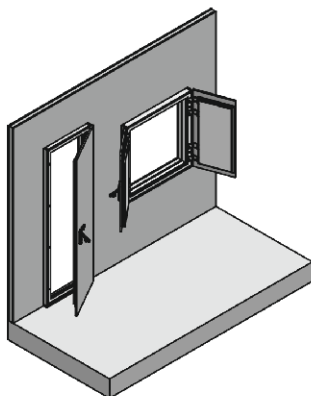

12 Final check

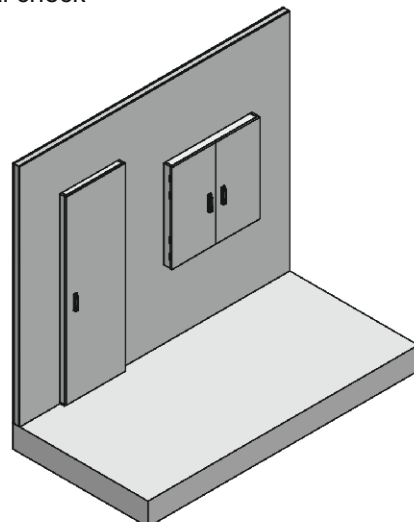

Assembly instructions for wall attachment - inspection doors (LWA-E-R) recessed option

1 Check that all the accessories are present

What is delivered:

- Wall attachment set
- 1-2 Two-way key(s)
- 1 x assembly instructions
- 1 x cartridge of fireproof cement



Tools required:

Hammer, spirit level, pallet truck, pliers, cordless screwdriver, bolt (Ø 2-3 mm diameter) drill with suitable bit (Ø 10 mm)

Visual and functional checks required directly after delivery:
Are the flexible seals round the cabinet closure mechanism in a perfect state?

Is the frame correctly assembled? Is the cabinet closure mechanism firmly attached to the frame?

Do the rotating levers close and lock?

Is the rating plate/production sticker attached?

Please note that the fire resistance capability of the LWA-E-R 30 is only guaranteed if the LWA-E-R 30 is always maintained in the condition prescribed in the certificate of suitability.

2 Description of the separating wall according to DIN 4102-4

The measurements for the opening in the separating wall match the outer measurements of the frame in the LWA-E-R 30.

Important: please ensure that you have a 90° angle when preparing the opening!

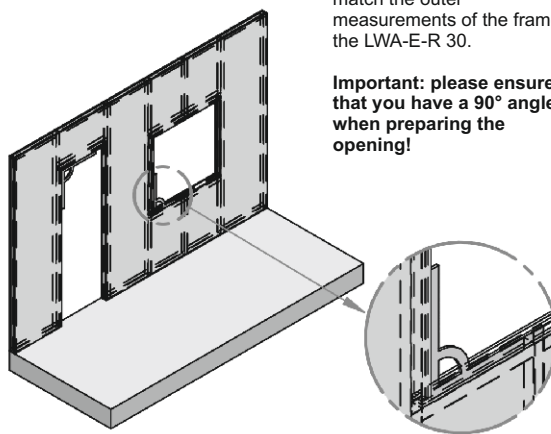

3 Separate the halves of the hinges

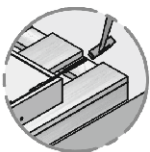
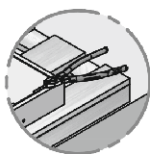
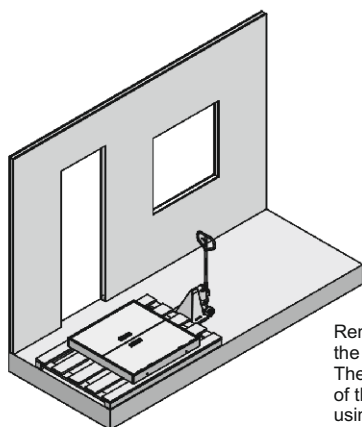

Remove the pin cap with the pliers.
The pin between the halves of the hinges is knocked out using the bolt.

4 Remove the cabinet closure mechanisms from the frame

The cabinet closure mechanisms are then loosened from the frame.
Do not unscrew the halves of the hinges!

Beware: the cabinet closure mechanisms must be stored horizontally in a flat area with the inside facing downwards!

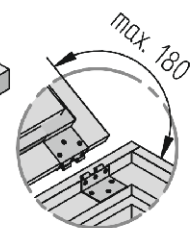
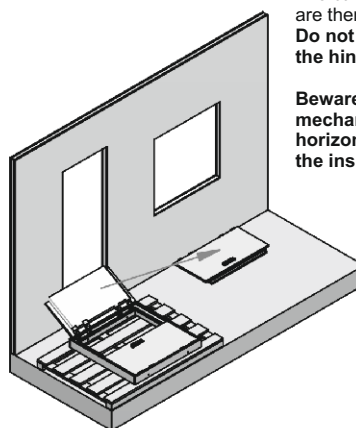

5 Straighten and position the frame and align it vertically and horizontally

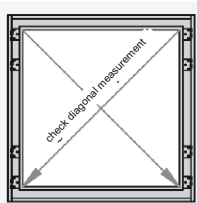
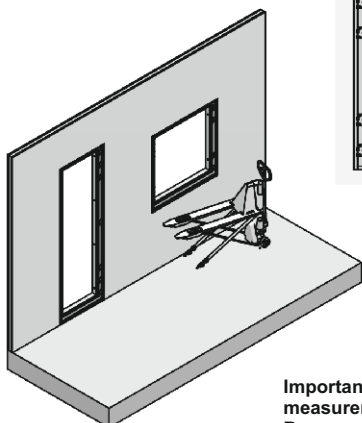

Important: check the diagonal measurements!
Beware: risk of breakage!

6 Prepare the attachment drill holes in the stud frame

Transfer the attachment drill holes (Ø 10 mm) in the stud frame through the pre-drilled holes in the frame.

Beware: risk of breakage!

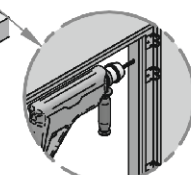
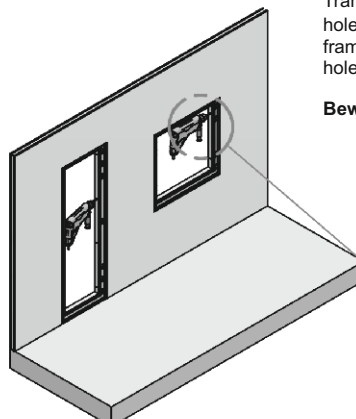

Assembly instructions for wall attachment - inspection doors (LWA-E-R) recessed option

7 Insert the metal frame dowels
Attach the frame in the separating wall

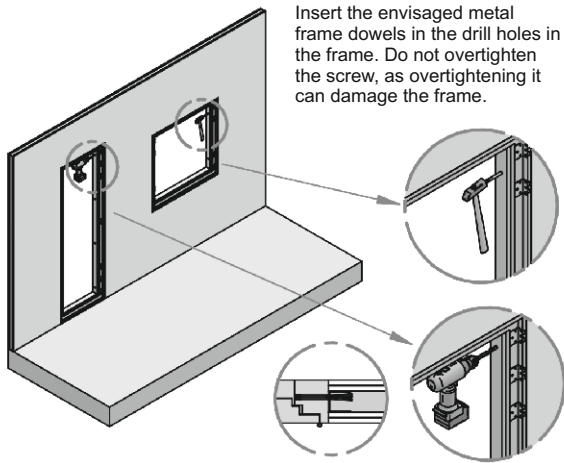

8 Insert the cabinet closure mechanism panel (left)

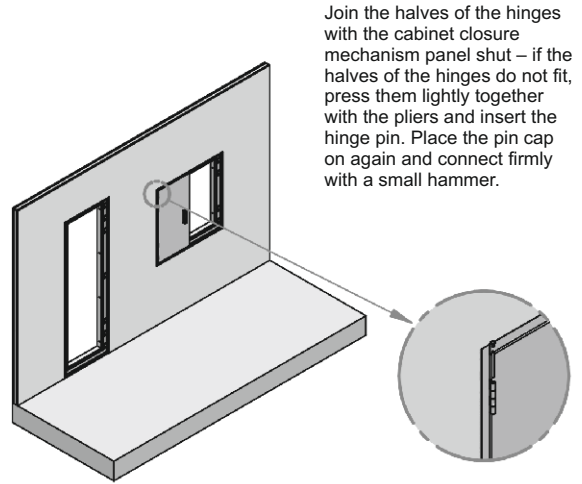

9 Insert the cabinet closure mechanism panel (right)

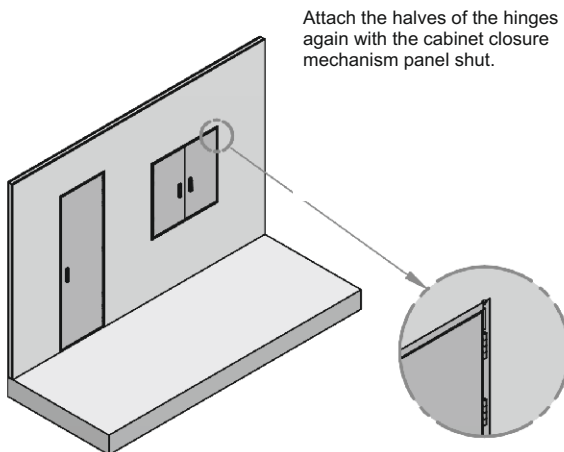

10 Seal the joints

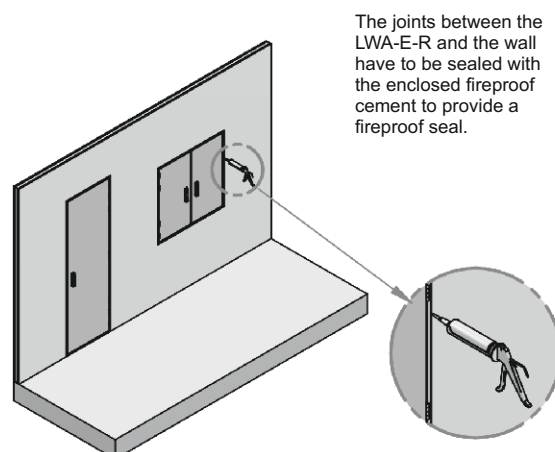

11 Check that the cabinet closure mechanisms work easily

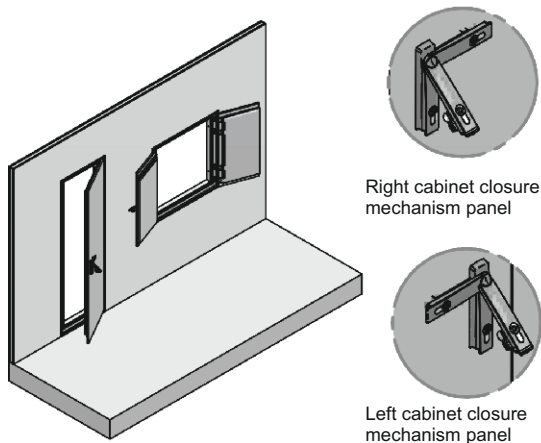

12 Final check

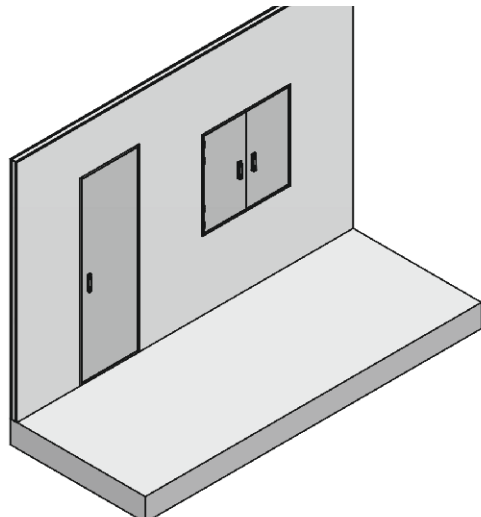

Assembly instructions for wall attachment - inspection doors (LWA-E-R) add-on option

1 Check that all the accessories are present

What is delivered:

- Wall attachment set
- Two-way key
- 1 x assembly instructions
- 1 x cartridge of fireproof cement

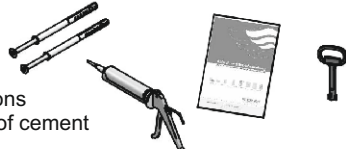

Tools required:

- Hammer, spirit level, pallet truck, pliers, cordless screwdriver, bolt (Ø 2-3 mm) drill with suitable bit

Visual and functional checks required directly after delivery:
Are the flexible seals round the cabinet closure mechanism in a perfect state?

Is the frame correctly assembled? Is the cabinet closure mechanism firmly attached to the frame?

Do the rotating levers close and lock?

Is the rating plate/production sticker attached?

Please note that the fire resistance capability of the LWA-E-R 30 is only guaranteed if the LWA-E-R 30 is always maintained in the condition prescribed in the certificate of suitability.

2 Description of the separating wall according to DIN 4102-4

The measurements for the opening in the separating wall match the inner measurements of the frame in the LWA-E-R 30 for both design options.

Please note too!

The height of the opening in the separating wall matches the inner measurement + 79 mm for the free-standing design option.

Important: please ensure that you have a 90° angle when preparing the opening!

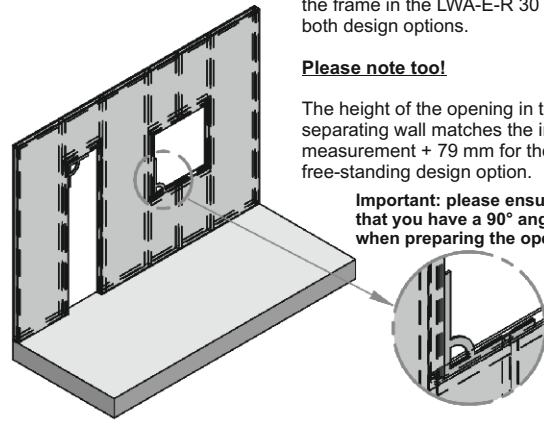

3 Separate the halves of the hinges

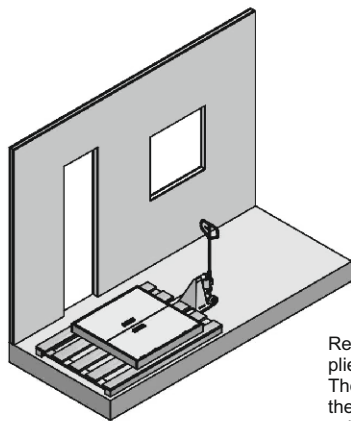

Remove the pin cap with the pliers.
The pin between the halves of the hinges is knocked out using the bolt.

4 Remove the cabinet closure mechanisms from the frame

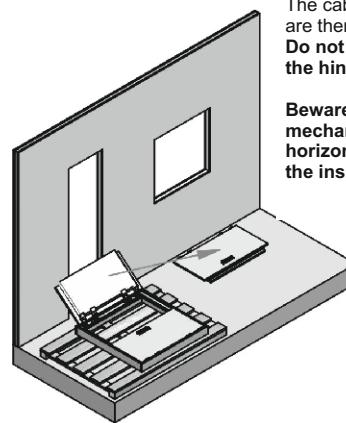

The cabinet closure mechanisms are then loosened from the frame.
Do not unscrew the halves of the hinges!

Beware: the cabinet closure mechanisms must be stored horizontally in a flat area with the inside facing downwards!

5 Straighten and position the frame and align it vertically and horizontally

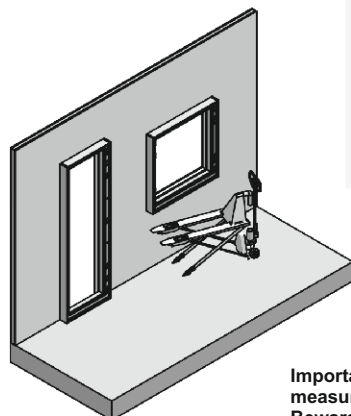

Important: check the diagonal measurements!
Beware: risk of breakage!

6 Prepare the attachment drill holes in the stud frame

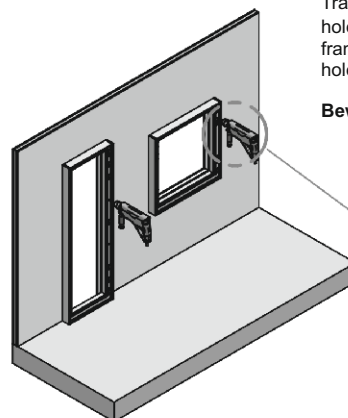

Transfer the attachment drill holes (Ø 10 mm) in the stud frame through the pre-drilled holes in the frame.

Beware: risk of breakage!

Assembly instructions for wall attachment - inspection doors (LWA-E-R) add-on option

7 Insert the metal frame dowels Attach the frame in the separating wall

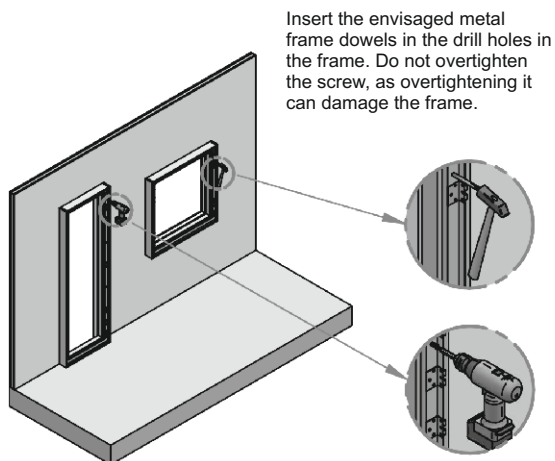

8 Insert the cabinet closure mechanism panel (left)

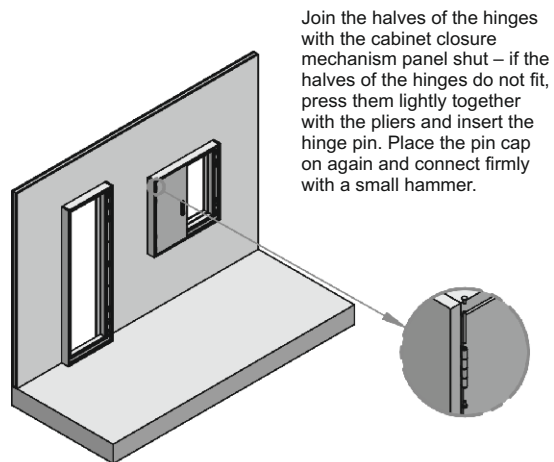

9 Insert the cabinet closure mechanism panel (right)

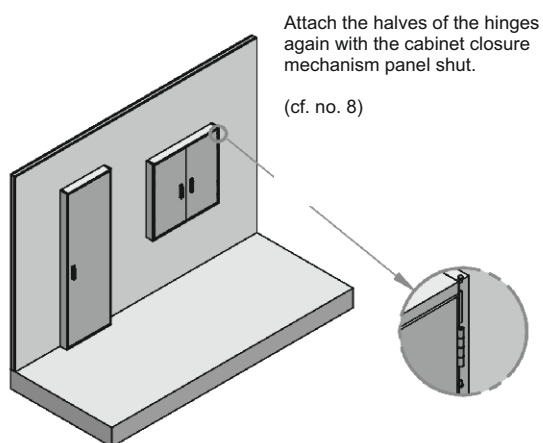

10 Seal the joints

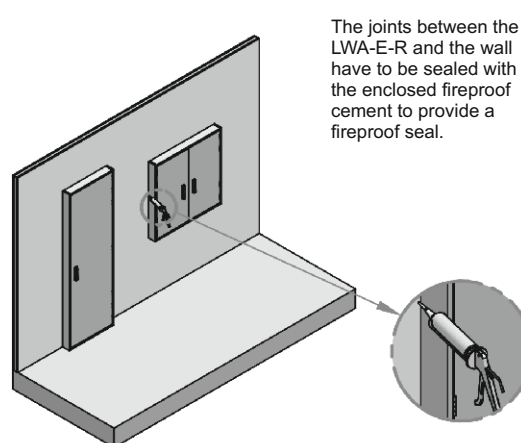

11 Check that the cabinet closure mechanisms work easily

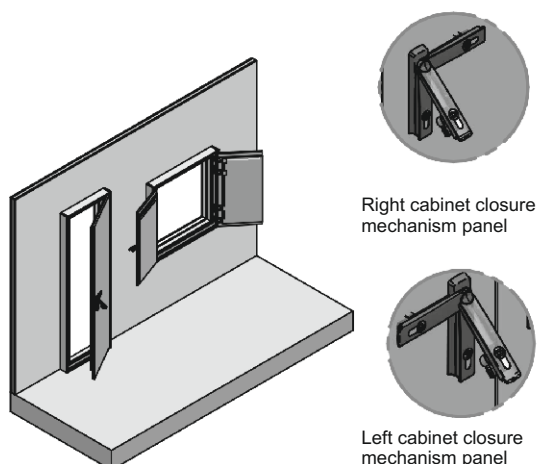

12 Final check

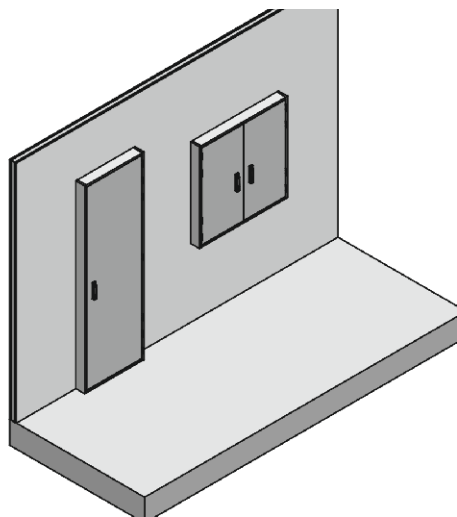

Assembly instructions for wall attachment - inspection doors (LEG-R) in shaft wall

Please note static requirements for the shaft wall system.

1

What is delivered:
M 5 x 60 mm attachment screws
1 – 2 keys
1 x operating instructions

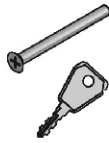

Tools required:
Folding ruler
Cordless screwdriver
Drill with suitable bit

Visual and functional checks required directly after delivery:

Are the flexible seals round the cabinet closure mechanism in a perfect state?
Is the frame correctly assembled? Is the cabinet closure mechanism firmly attached to the frame?
Do the rotating levers close and lock?
Is the rating plate/production sticker attached?

Please note that the fire resistance capability of the LEG-R 30/60 is only guaranteed if the LEG-R 30/60 is always maintained in the condition prescribed in the certificate of suitability.

2

Create the shaft wall according to a general building supervision permit (abZ)

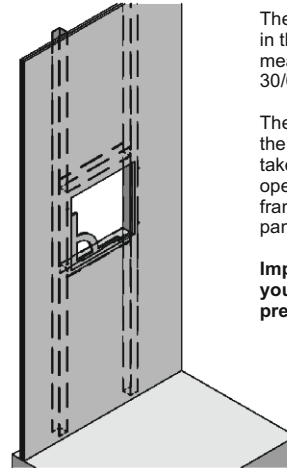

The measurements in the opening in the shaft wall match the outer measurements of the LEG-R 30/60.

The additional fireproof panel on the top of the LEG-R 30/60 is not taken into consideration in the opening measurement; the stud frame must be adapted to this panel.

Important: please ensure that you have a 90° angle when preparing the opening!

3

Insert in the shaft wall in the direction of escape

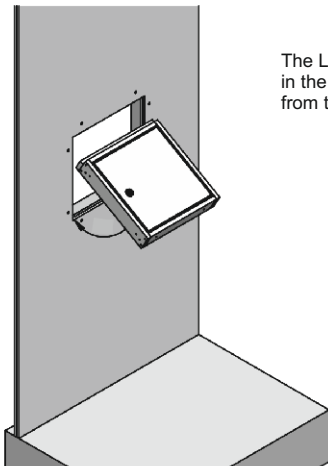

The LEG-R 30/60 is inserted in the opening by pushing from the bottom upwards.

4

Align vertically and with the shaft wall

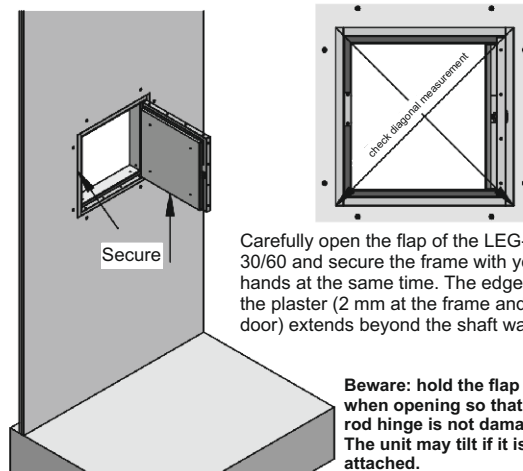

Carefully open the flap of the LEG-R 30/60 and secure the frame with your hands at the same time. The edge of the plaster (2 mm at the frame and door) extends beyond the shaft wall.

Beware: hold the flap tightly when opening so that the rod hinge is not damaged. The unit may tilt if it is not attached.

5

Attach and complete the assembly work

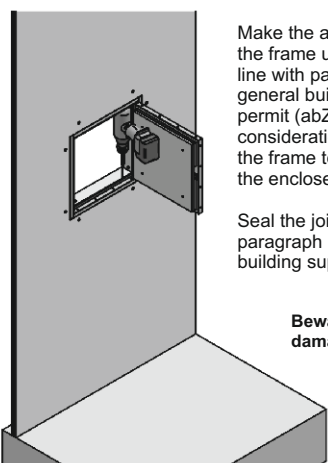

Make the attachment drill holes in the frame using a suitable drill in line with paragraph 3.2.2.4 of the general building supervision permit (abZ), taking into consideration the profile. Attach the frame to the shaft wall using the enclosed attachment material.

Seal the joints according to paragraph 3.2.2.4 of the general building supervision permit (abZ)

Beware: overtightening can damage the frame!

6

Final check

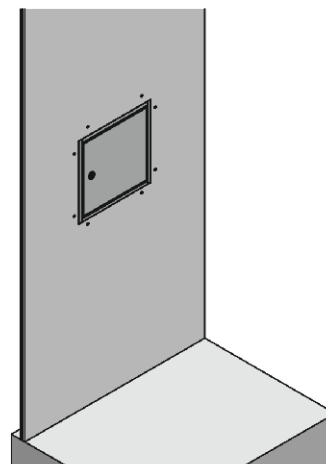

Assembly instructions for small distribution boards – wall attachment

(CK / CV)

1. Check that all the accessories are present:
 - 2 - 4 x wall attachment sets
 - 1 x operating instructions
 - 1 x maintenance checklist (see page 61)
2. Place the small distribution board at the prescribed assembly height.
3. Vertically align the small distribution board on the wall or ceiling (ceiling assembly only possible with CK 30 system). Project surveys on ceiling assembly must be checked by the customer in the planning phase.
4. Mark the drill holes on the wall through the pre-drilled holes on the distribution board. Drill the marked drill holes about 110 mm deep in the building wall with a masonry drill (diameter = 10 mm). (Shorter dowels available for tunnels). (Enclosed dowel: 10 x 135 mm or 10 x 80 mm).
5. Extract the drill dust, tap in the dowel (flush with the screw head) and tighten the screw with a suitable screwdriver.
Beware: overtightening can damage the frame.
6. Place the plastic caps on the attachment anchor (optional) and press on firmly. (optional)
7. Coat the plastic caps on the attachment anchor with fireproof cement (Crystal-CEL) to guarantee the type of protection. (optional)



Small distribution board (CK 30)

Loosen the quick-action locks to open the small distribution board so that the lid can be removed.

Important: The lids are ideally adapted to the cabinet. Please avoid any swapping of the lids. With a rotating lever too. (optional)

Take care: the lid is not secured after having been opened!

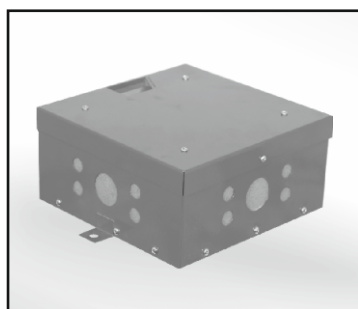

Junction box (CV 30)

Please loosen the two screws opposite each other on the sides of the lid to open the junction box.

Take care: the lid is not secured once it has been opened!



Small distribution board (CK 90 - T/ CK 90 - D)

Please remove the four screws on the sides of the lid to open the small distribution board or open using a swivelling lever.

If assembling in tunnels with a curved surface, the joint between the CK / CV and wall must be filled with fireproof cement (Crystal-CEL).

Using the fireproof cable entry point

Type "A"

2 x 40 mm Ø
12 x 18 mm Ø

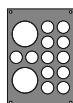

Type "B"

2 x 40 mm Ø
32 x 18 mm Ø

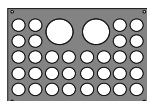

Type "C"

1 x 30 mm Ø
2 x 40 mm Ø
1 x 60 mm Ø
21 x 18 mm Ø

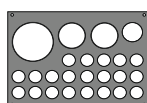

Type "D"

6 x 30 mm Ø
1 x 40 mm Ø
1 x 60 mm Ø
1 x 80 mm Ø

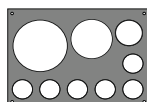

Type "E"

2 individually usable areas



Type "F"

15 x 18 mm Ø
1 individually usable area

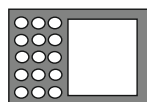

Type "G"

1 individually usable area



The cable entry point as a system component for an electrical cabinet consists of:

- a) a metal cover,
- b) the insulating layer creator and endothermic areas

The metal cover with various dimensions, depending on the type of distribution board, has drill holes.

The cables must be fed through these drill holes in line with their outer diameter.

The insulating layer creator that is visible through the drill holes must be carefully pushed through with a cordless drill (with a drill bit that is about 2 mm smaller than the diameter of the cable) – this makes it easier to introduce the cable. When pushing through the red or blue insulating layer creator, please note that the cordless drill must be fed in straight.

To achieve tension relief on the cables, a cable duct must be assembled on the device support in the cabinet and directly in front of the cable entry point outside the cabinet; the cables are then attached to it.

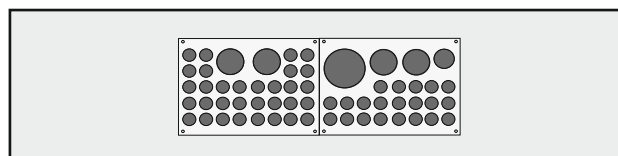

Example for illustration purposes:

Cable entry point with blue insulation layer former (standard design)

The diameter of the cables must be 2 mm smaller than the opening in the cable entry point. The instructions for using the cable entry point do not absolve you from following the general guidelines for routing cables.



Optional sheath for reinstalling simply.

Assembly instructions for cable entry point (CKE)

1. Carefully drill through the red or blue visible insulating layer creator with a cordless screwdriver and pass through the opposite drill hole in the interior of the distribution board. The drill diameter must be 2 mm smaller than the diameter of the cable. 2 mm of insulating layer creator are necessary around the cable. The distance between two cables must be 4 mm (e.g. in the individually usable area).
2. Strip the cable, attach to the cable pull cord, draw through the insulating layer creator and feed into the distribution board.
3. Connect the cable in the distribution board.
4. Attach the cable to a cable rail to maintain its function/fire resistance and to ease the tension on it inside or outside the distribution board. (This is not absolutely essential. The distribution board has been tested and approved without a cable rail.) The cable must not be laid directly next to the edge of the metal cover or the inner fireproof panel.
5. Check that the cable entry point fits correctly.

Please note: If necessary, the cable entry point can be sealed with Crystal-Cel fireproof cement in order to maintain the IP protection class.

Cable entry point – add-on enclosures

(LWÜ)

Cables can be inserted below the plaster for the LWÜ series add-on enclosures like the CWA and LWA series.

The LWÜ can already be provided with a “CKE” cable entry point at the factory and cables can be fed into the interior of the cabinet through this.

The principle matches the free-standing and wall distribution board series from Celsion. The CKE is pierced with a screwdriver or a thin drill and the cable is fed into the cabinet (see page 35).

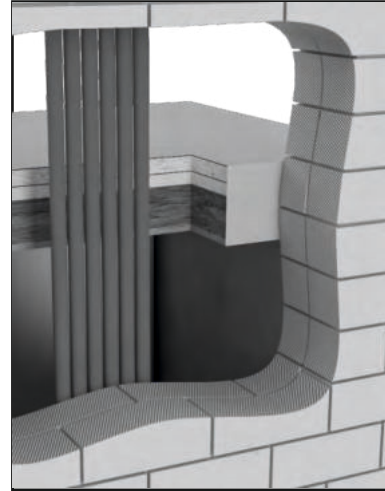

Cut-out for existing cables

There is another way to feed in cables without shutting down the unit if cables already exist.

Before assembly, a cut is made for this flush on the wall, at the top or bottom – depending on the course of the cables.

After assembly, the cut is lined with a mineral wool block again and covered with a special coating in order to enable the fire resistance and the maintenance of functions in this solution too.

Existing cable routes must end outside the cabinet and may not protrude into the cut.



Cut-out from underneath

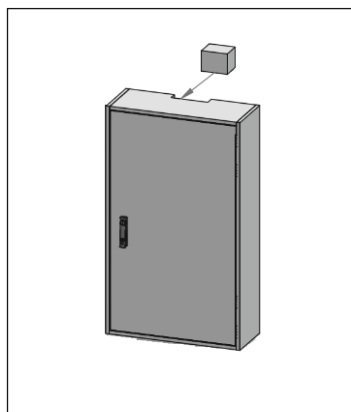

Mineral wool block is added to the system

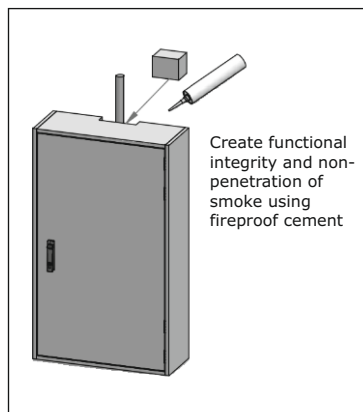

Insert mineral wool block again when assembling

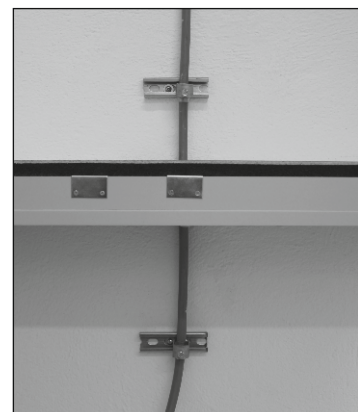

Finished assembly work with cut for existing cables

Cable box

Violution 90

1 Check that all the accessories are present

What is delivered:
Cable box
Solid material
Attachment screws
Size 4.5 x 60

Tools required:
Cordless screwdriver
Drill sized 3.5 x 60

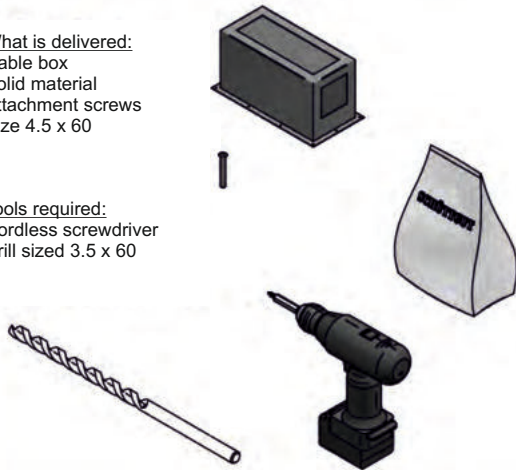

2 Prepare the cable box

Remove the upper fireproof pad

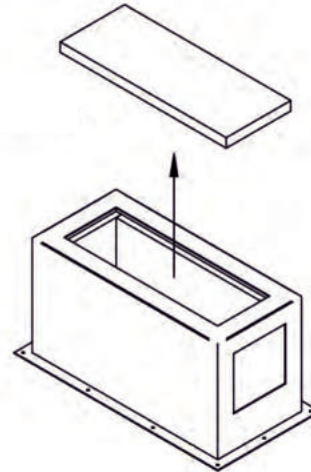

3 Drill holes for cables in the insulation and cabinet

Place the insulation in the cable box in the middle above the cable entry point next to the fireproof pad and then drill the holes for the cables.

Please note:
cables may only be fed into the fireproof box in the area envisaged for the opening.

Maintain the minimum distance!

From cable to cable: ≥ 4 mm
The size of the drill holes must be 2 mm smaller than the diameter of the cables being fed in.

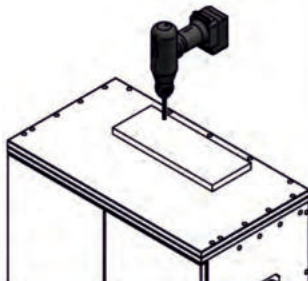

4 Feed the box over the cables

Feed the cables through the drill holes of the fireproof pad and the cable box

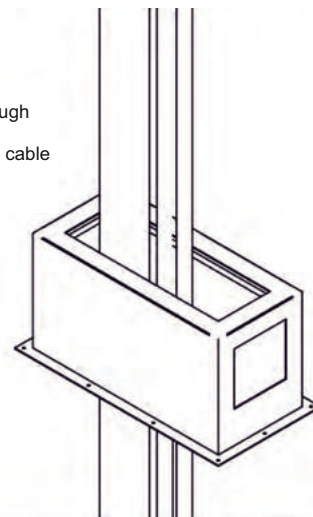

5 Feed the cables into the fireproof cabinet

Part of the cable entry point manufactured at the factory

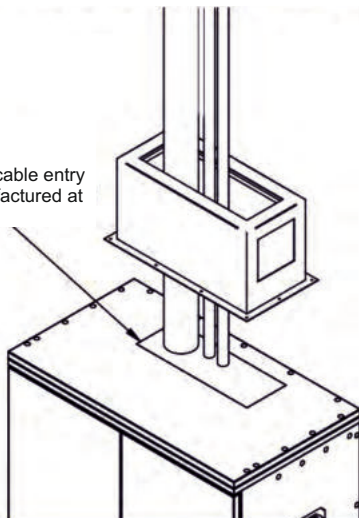

6 Attach the cable box on three sides

Please note:
do not overtighten the screws!

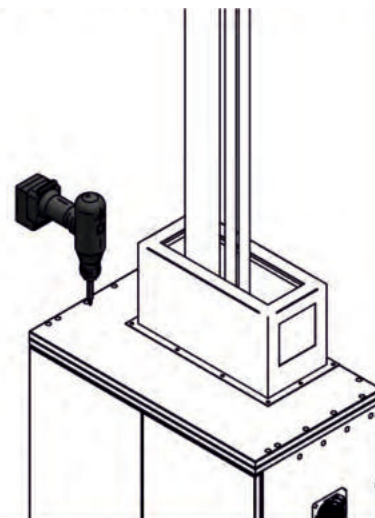

Cable box

Violution 90

7 Pour in the dry solid material evenly

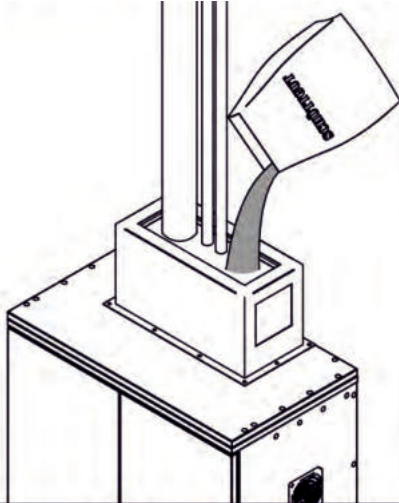

8 Insert the fireproof pad

Press the upper fireproof pads into the cable box again so that the cables are fully surrounded (possible separation is permissible).

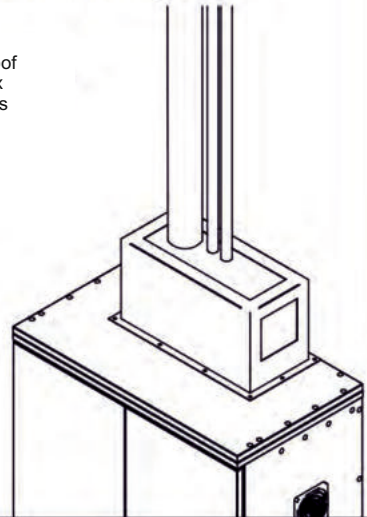

9 Attach the cables

Attach cables to the wall according to the standard

Example

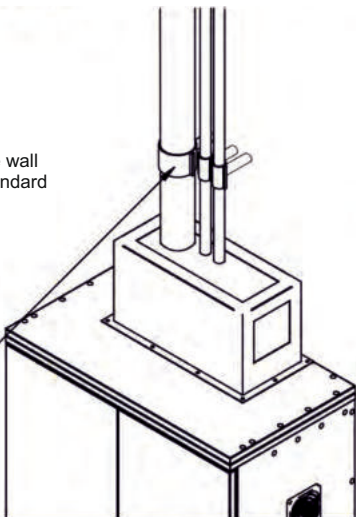

10 Final check

Tighten and check the position of the fireproof pad

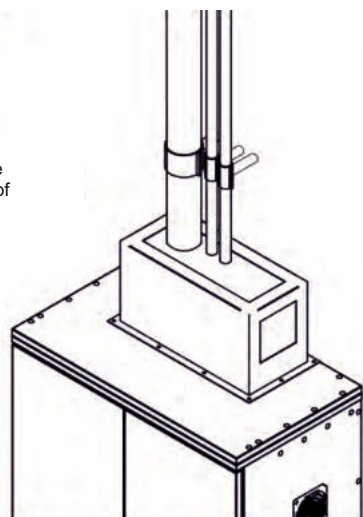

Assembly instructions

Duct connecting piece

1 Materials

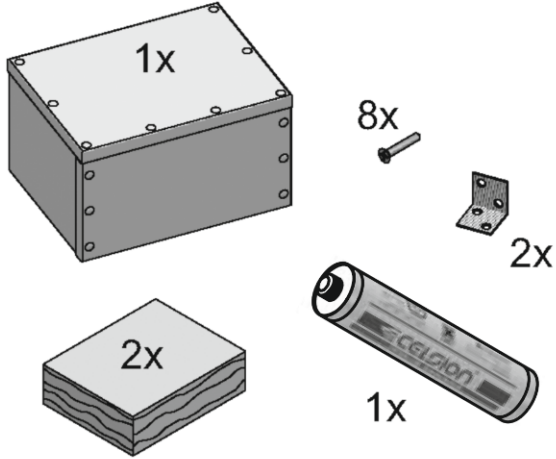

2 Tools

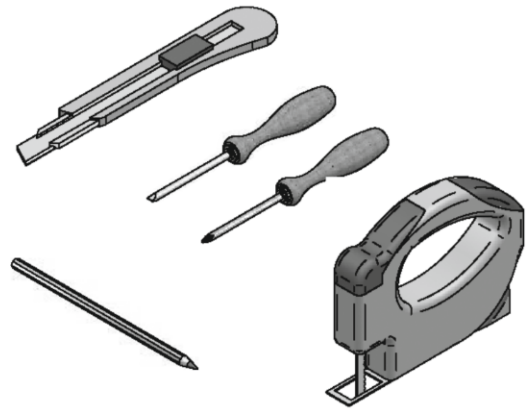

3

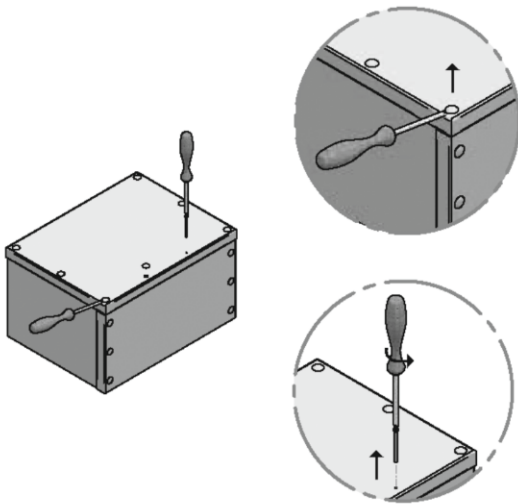

4

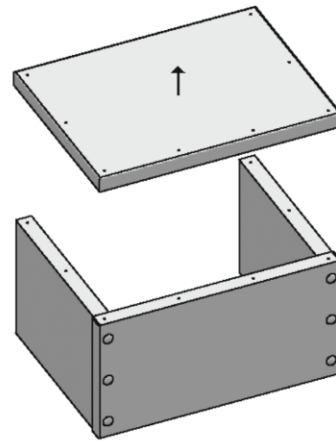

5

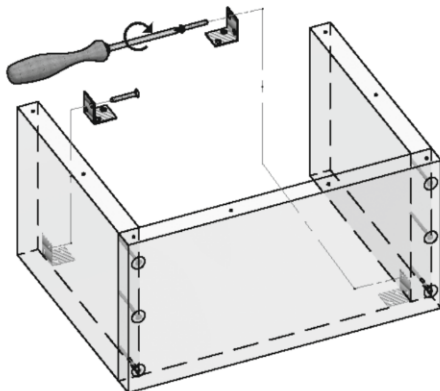

6

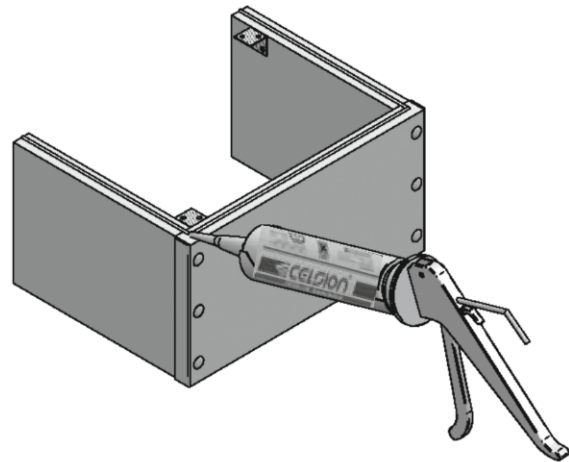

Assembly instructions

Duct connecting piece

7

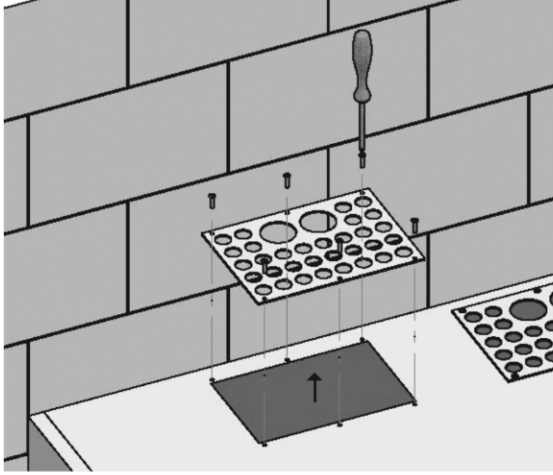

8

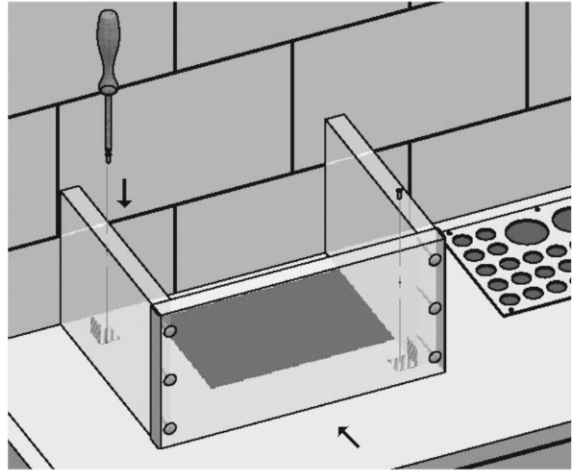

9

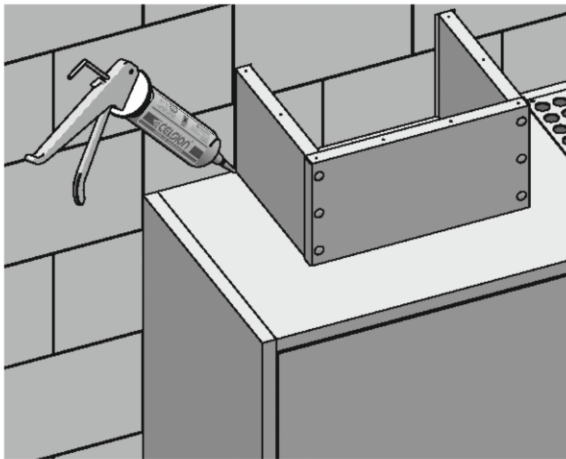

10

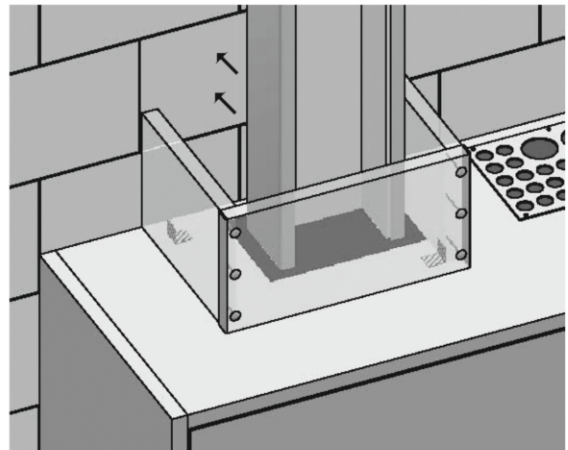

11

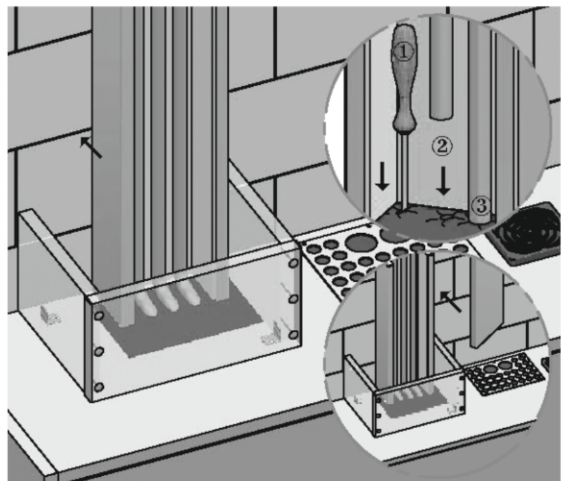

12

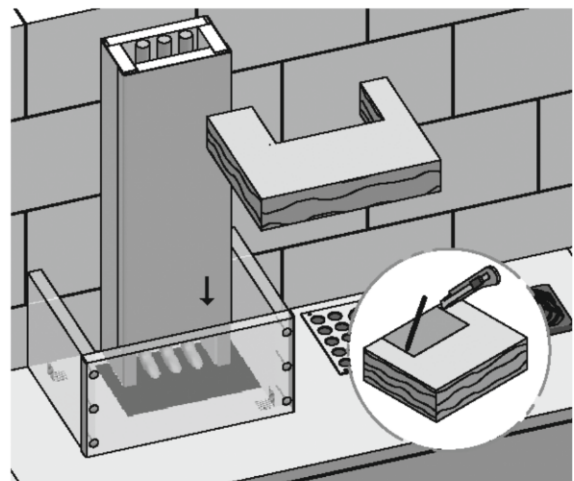

Assembly instructions

Duct connecting piece

13

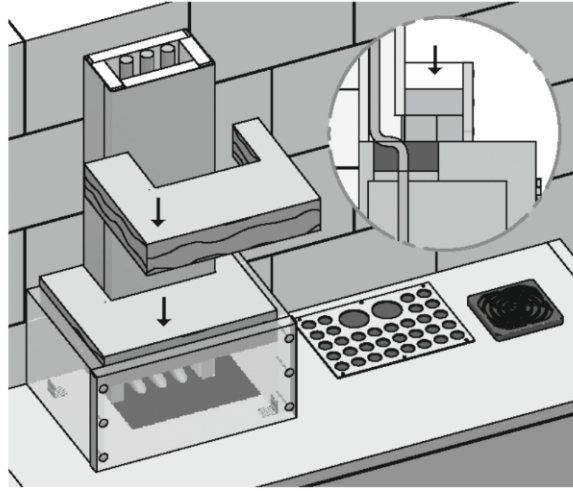

14

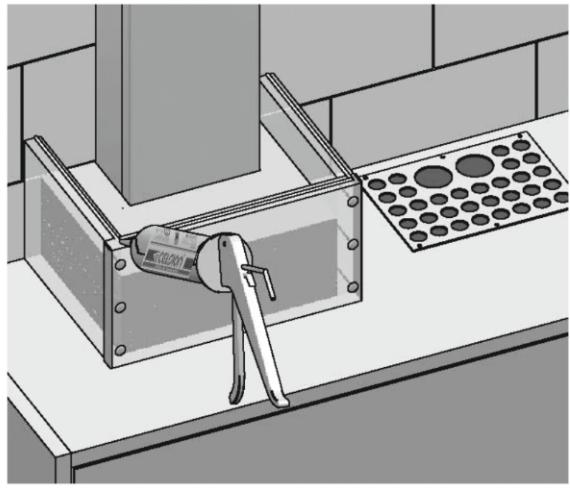

15

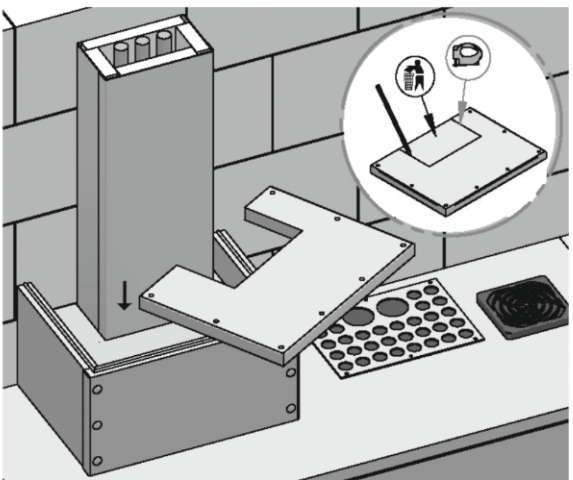

16

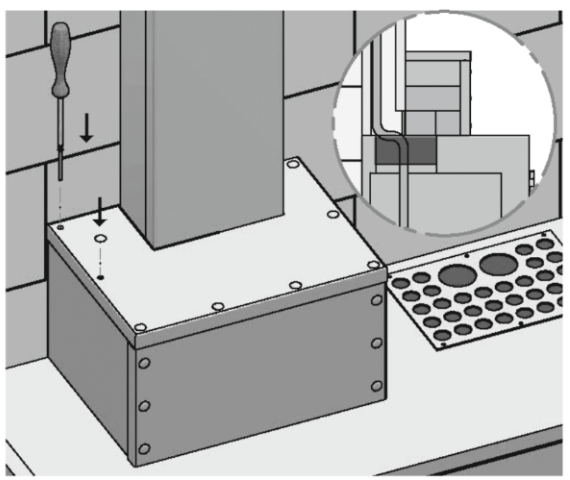

17

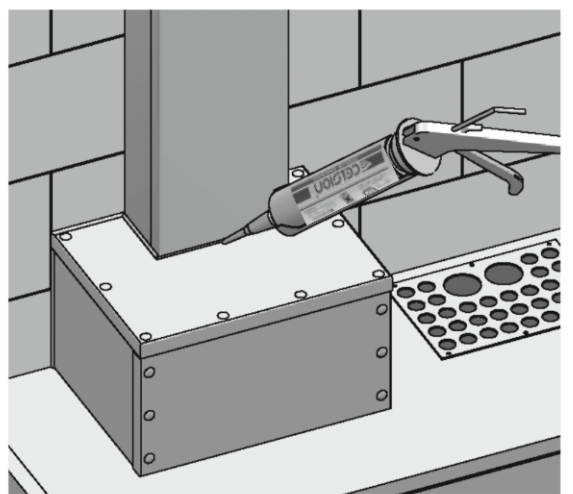

18

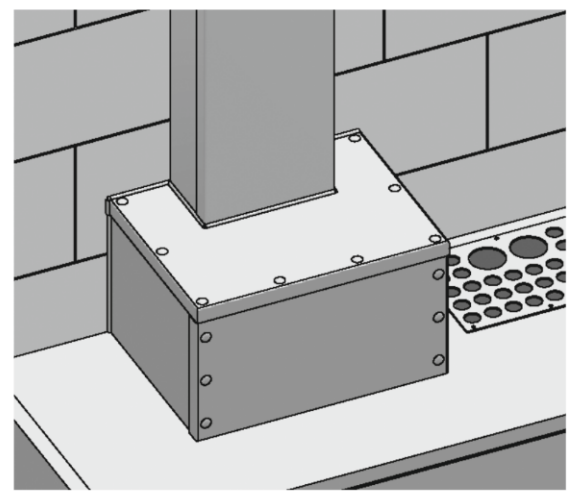

Assembly instructions

Duct connecting piece

19

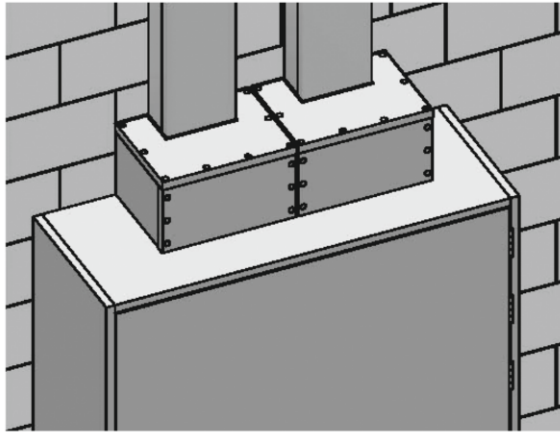

20

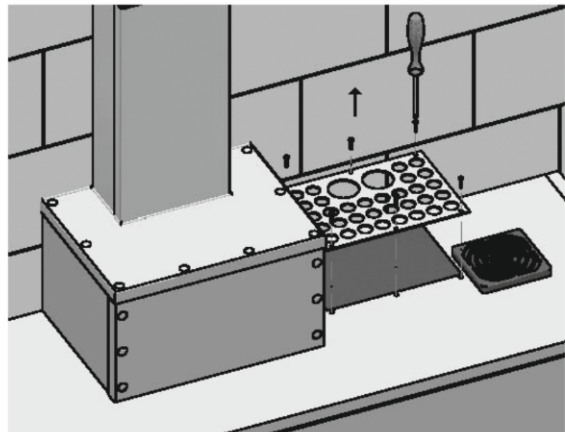

21

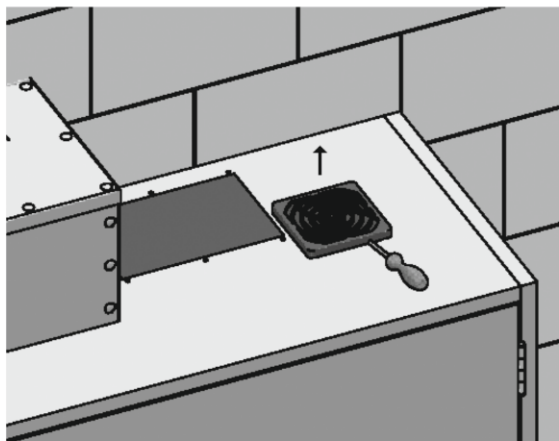

22

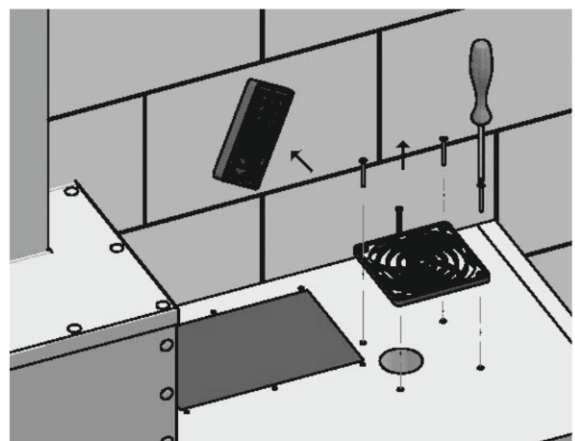

23

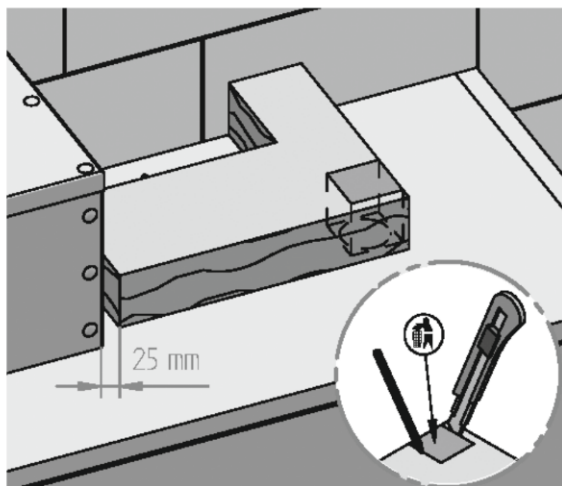

24

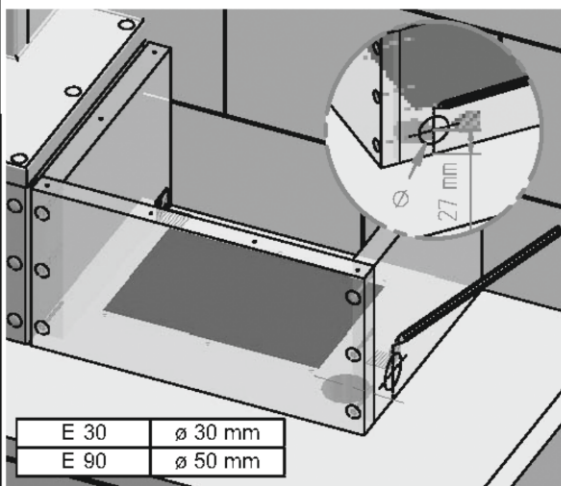

E 30	ø 30 mm
E 90	ø 50 mm

Assembly instructions

Duct connecting piece

25

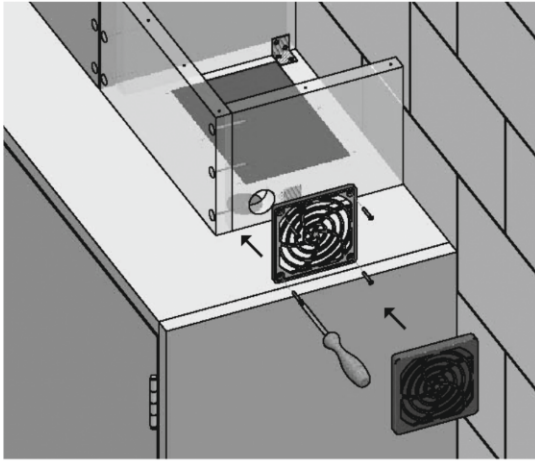

26

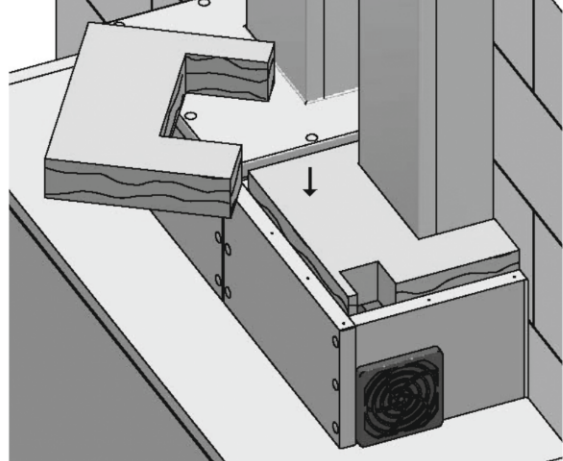

27

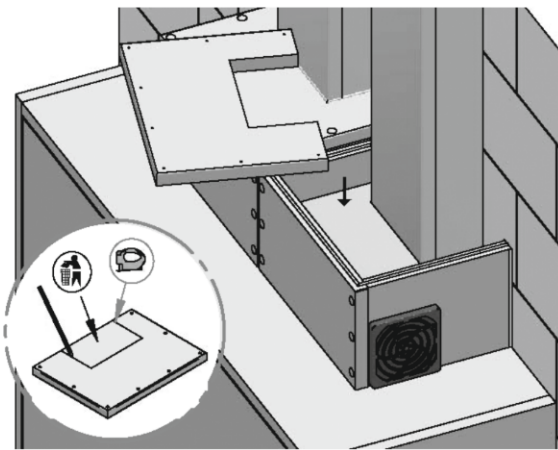

28

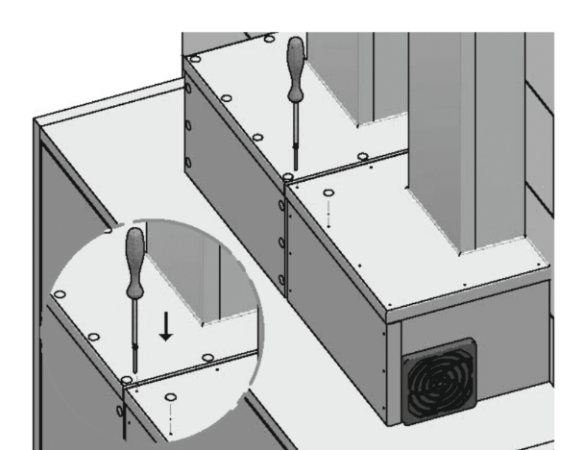

29

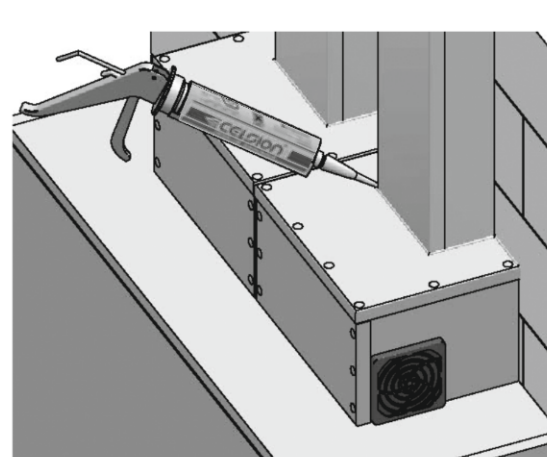

30

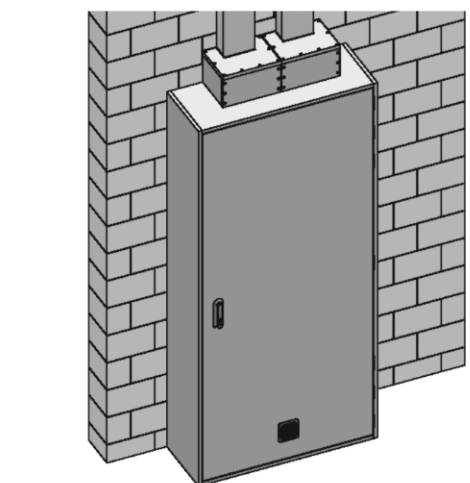

Setting up a metal base

1 Check that all the accessories are present

What is delivered:
Wall attachment set
Two-way key(s)
Setup and operating instructions



Tools required:

Spirit level, cordless screwdriver, drill with suitable bit, provisional base

Visual and functional checks required directly after delivery:
Are the flexible seals round the cabinet closure mechanism in a perfect state?
Is the frame correctly assembled? Is the cabinet closure mechanism firmly attached to the frame?
Do the rotating levers close and lock?
Is the rating plate/production sticker attached?

Please note that the fire resistance capability of the Celsion fireproof cabinet is only guaranteed if the Celsion fireproof cabinet is always maintained in the condition prescribed in the certificate of suitability.

2 Align the base

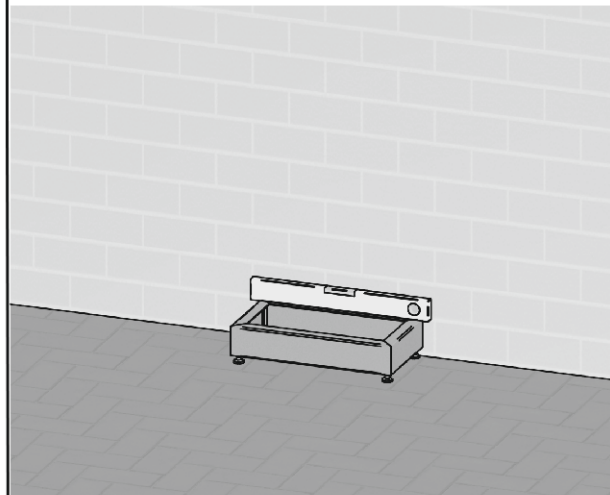

3 Lay a pallet or something similar about 15 mm higher than the base in front of it

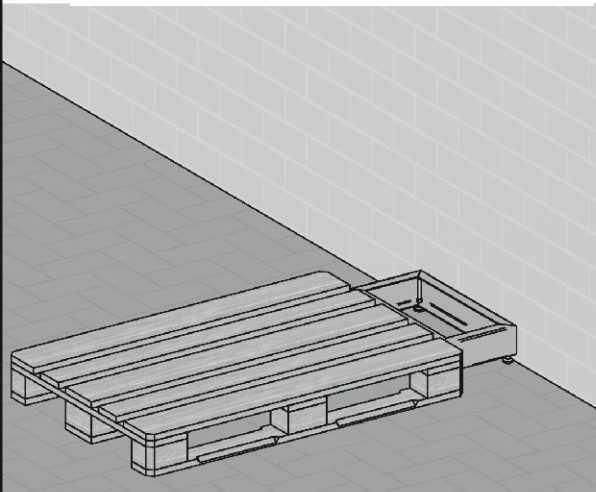

4 Set up the fireproof cabinet on the temporary base – a pallet, for example

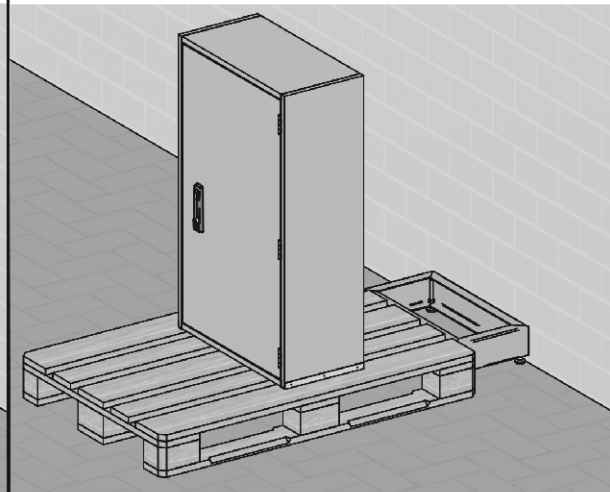

5 Push the fireproof cabinet precisely and carefully from the temporary base on to the base

Beware: the unit may tip over if the door is closed!

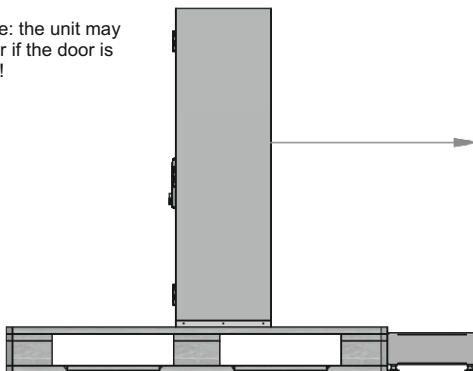

6 Align the base once again by adapting the adjustable feet

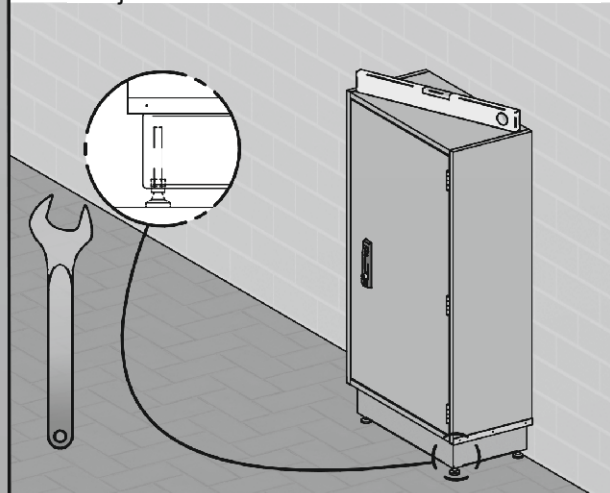

Setting up a metal base

7 Check the gap on the wall side



8 Tilt protection: drill the attachment drill holes in the wall

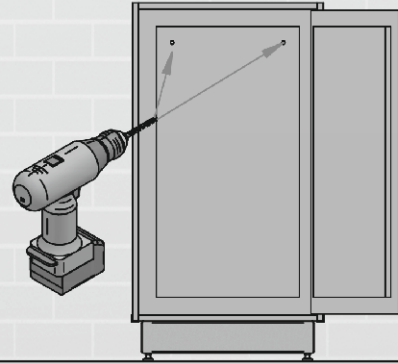

9 Attach the fireproof cabinet to the wall (push-through installation)

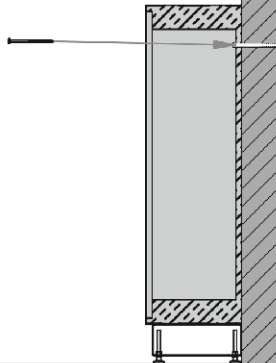

10 Complete a final check to see whether the fireproof cabinet is level

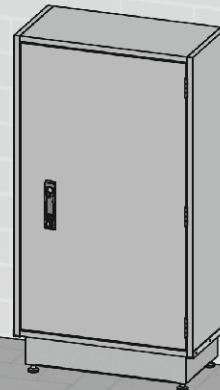

Setting up a base

Violution 90

1 Check that all the accessories are present

What is delivered:

- 1 x wall attachment set
- 1 – 2 two-way key(s)
- 1 x setup and operating instructions

Tools required:

Spirit level, cordless screwdriver, drill with suitable bit, provisional base

Visual and functional checks required directly after delivery:
Are the flexible seals round the cabinet closure mechanism in a perfect state?

Is the frame correctly assembled? Is the cabinet closure mechanism firmly attached to the frame?

Do the rotating levers close and lock?

Is the rating plate/production sticker attached?

Please note that the fire resistance capability of the Violution series is only guaranteed if the Violution series is always maintained in the condition prescribed in the certificate of suitability.

2 Align the base

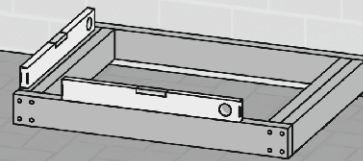

3 Lay a pallet or something similar in front of the base (about 15 mm higher than it)

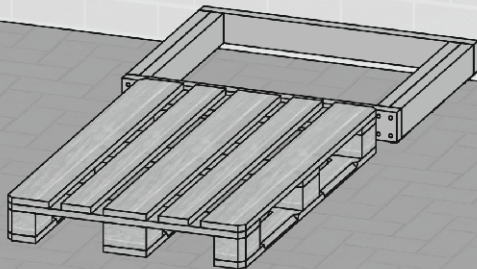

4 Set up the fireproof cabinet on the temporary base – a pallet, for example

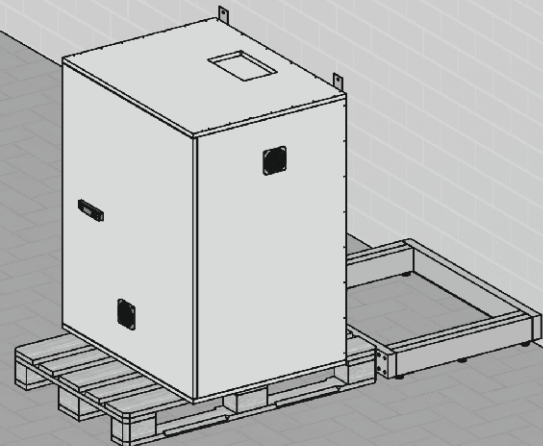

5 Push the fireproof cabinet precisely and carefully from the temporary base on to the base



6 Align the base once again by adapting the adjustable feet

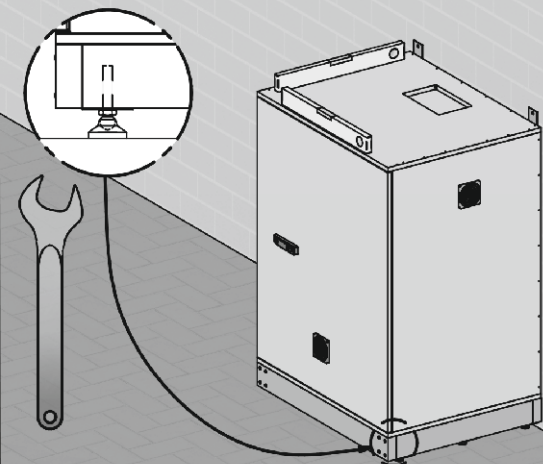

Setting up a base

Violution 90

7 Check the gap on the wall side

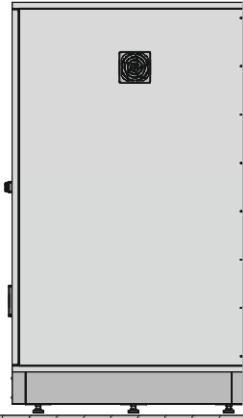

8 Tilt protection: drill the attachment drill holes in the wall

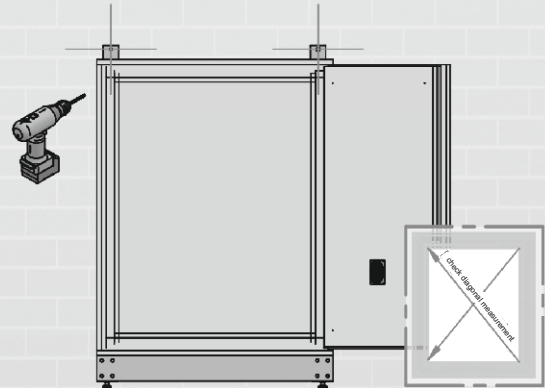

9 Attach the fireproof cabinet to the wall

push-through installation

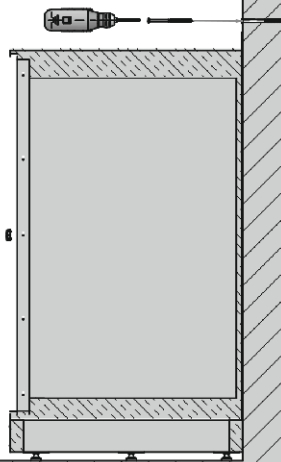

10 Complete a final check to see whether the fireproof cabinet is level

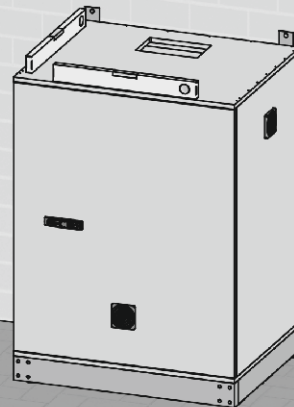

11 Assemble the cable box

See separate instructions for
"Violution 90 cable box"...

Using the height-adjustable base

This metal base has been tested and approved by the Material Testing Agency in Stuttgart in conjunction with a free-standing distribution board. Please note the general building supervision permit no. 86.1-23 on this, for example.

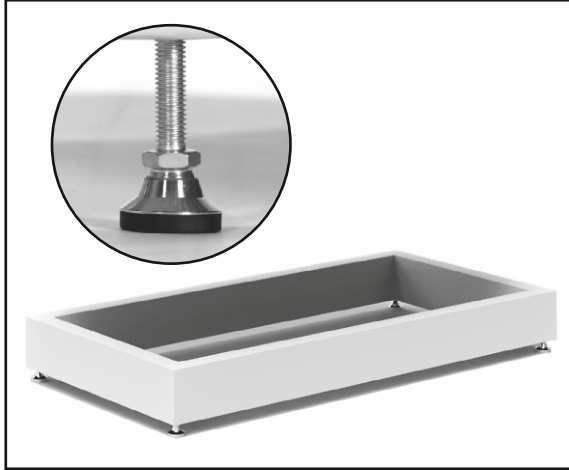

The height of the base is 100 mm and its height can be adjusted by the enclosed levelling feet by **125 to 150 mm**.

The dimensions of the base in its width and depth result from the outer dimensions of the distribution board.

- **Width of the distribution board -60 mm**

= width of the base

- **Depth of the distribution board -20 mm**

= depth of the base

Please consult the latest price list with images!

Example:

Distribution board CS 12.1-30 M

(HxWxD 2050 x 478 x 400 mm)

Suitable base .

Width: 418 mm x depth 380 mm

Conditions for assembling the base:

1. The subsurface must be clean, dry, solid and even.

The threaded screws of the levelling feet must be screwed into the threaded holes in the base. Adjust the height by turning the base feet into the base.

2. A connection between the base and the distribution board must not be created, as differentiating length expansion has to be considered because of the different materials.

Ventilation system (KLS / VLS)

The KLS/VLS ventilation system has a standard size of 40 – 80 mm. Because of its special design, the ventilation system automatically closes through the expanding behaviour of the fireproof materials inside the systems.

View of KLS/VLS from inside

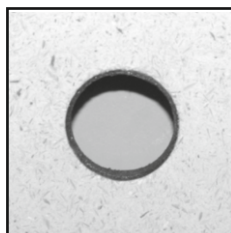

View of KLS/VLS from outside



Functional sketch of KLS

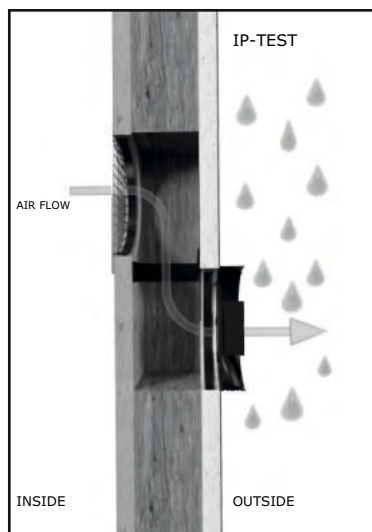

Ventilation system

CLS (80 mm) and KLS/ VLS (40 mm, optionally 80 mm)

The CLS and KLS/VLS ventilation system (natural ventilation system) works on the basis of the different air flows caused by the temperature differences inside and outside the distribution box. No energy source is required. A difference between the two ventilation systems basically exists in the closure behaviour if a fire breaks out.

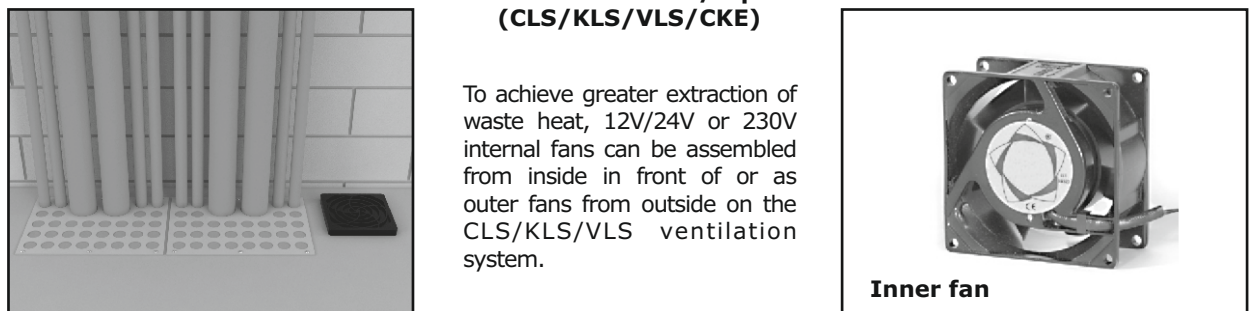
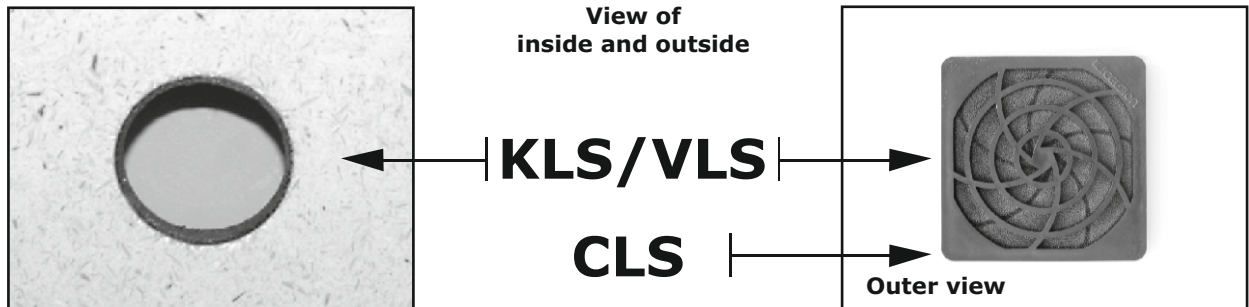
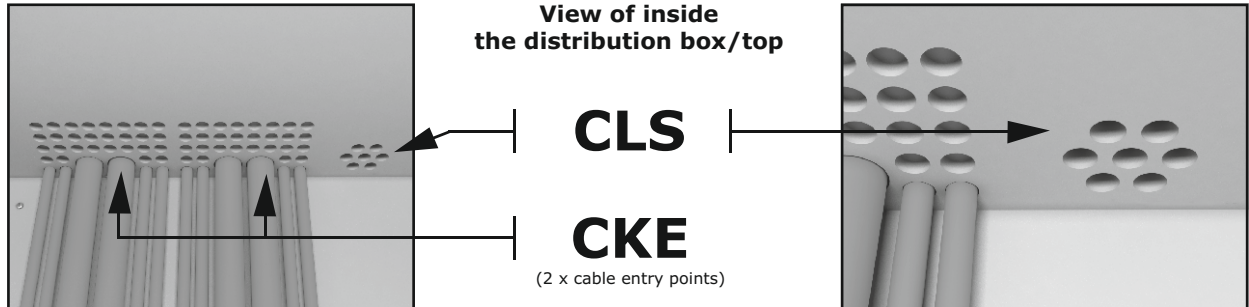

If the smaller fans are inadequate to extract the heat loss, it is possible to assemble the DVS roof fan as a high-performance fan from outside on the top of the distribution box. The black grill of the CLS/KLS/VLS is simply removed and the fan is screwed on to the cabinet. To achieve airtightness, the connection between the distribution box and the fan must be sealed with silicone. The power supply is provided via the cable entry point, for example.

Connecting the DVS roof fan with two speeds

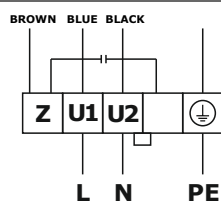

Connection for high speed

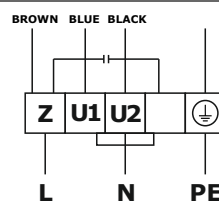

Device wiring

Connection for low speed

Performed by building manager

Assembling the outer fan

(DVS - roof fan – high-performance fan)

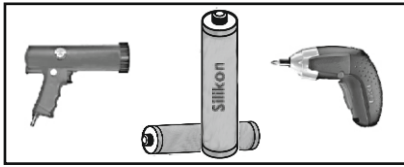

1. Prepare working tools (not included in the delivery)
 - Cordless screwdriver (with Phillips screw head)
 - Cartridge gun
 - Normal silicone

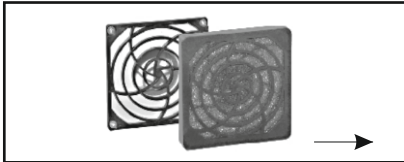

2. Remove the complete black grille from the CLS/KLS/VLS unit on the top of the cabinet.

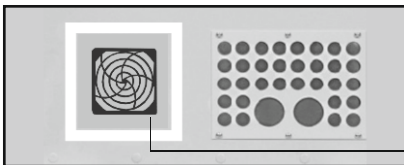

3. Position the fan as close to the middle as possible above the fan opening.

→ Remove this grille – see paragraph 2!

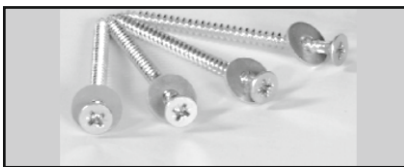

4. Screw the fan to the distribution box cabinet (attachment materials enclosed). Please note: pre-drill!
5. Seal the fan with normal silicone around the fireproof cabinet.

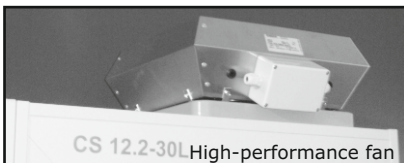

6. Now link up the power supply to the fan by feeding the power cable into the distribution box through the cable entry point and connect it. The wiring diagram on page 49 must be followed.

Assembling the outer fan

(Assembly set for DVS fan)

1 Check that all the accessories are present

What is delivered:

- 1 x sealing rubber for L = 1340 mm
- 2 x stainless steel mounting brackets L = 290 mm
- 2 x self-adhesive rubber strips
- 4 x 3.9 x 19 mm screws
- 4 x 3.5 x 13 mm self-tapping screws
- 4 x rubber sealing plugs

(DVS roof fan is not included in the delivery)

Tools required:

- Screwdriver
- Cordless screwdriver
- Drill \varnothing 2.5 mm

2 Seal the internal assembly drill holes of the DVS roof fan

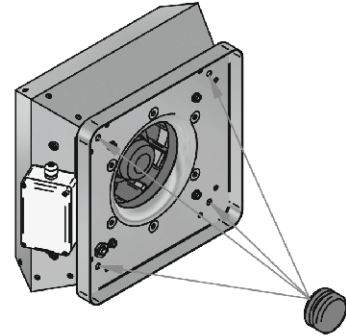

Seal the four drill holes on the bottom side in the intake area with the rubber sealing plugs

3 Place the sealing rubber on the fan

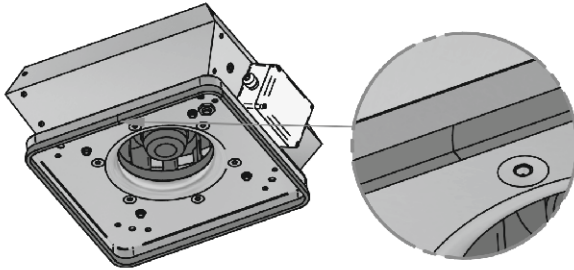

Place the sealing rubber on the edge of the fan assembly metal without any tensile stress.

The joint must be flush and seal it!

The protruding end should be cut +5 mm longer.

4 Prepare the mounting bracket

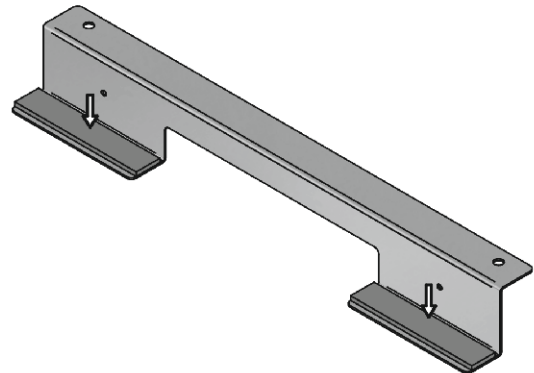

Attach the enclosed rubber strips on to the mounting bracket on the insides that rest on the DVS fan.

If necessary, trim the rubber strips to fit. The rubber is used for noise insulation and preventing any slippage.

5 Remove the filter cartridge

If necessary, remove the black filter cartridge completely from the top of the cabinet.

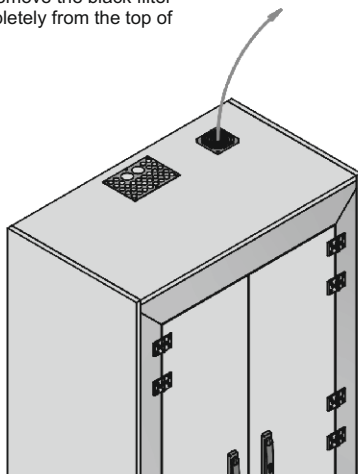

6 Position the fan

Position the mounting bracket opposite to each other around the DVS fan, depending on the space available, and attach it to the cabinet using the enclosed screws.

Recommendation: drill no more than 15 mm deep with the \varnothing 2.5 mm drill bit.

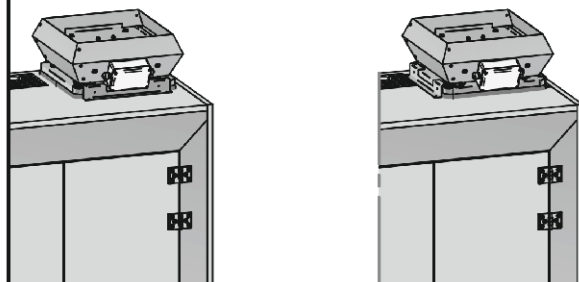

Assembling the outer fan

(Assembly set for DVS fan)

7 Position the fan

A mounting bracket must be assembled at the top and bottom to mount the DVS fan vertically, for example on the side of the cabinet.

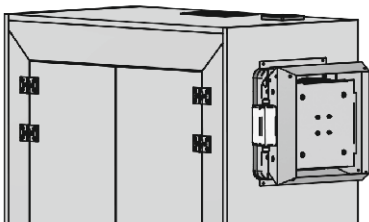

8 Fasten the mounting bracket to the fan

Fasten the mounting bracket to the fan at the 3 mm drill holes on the side using the 3.5 x 13 mm self-tapping screws. The rubber seal on the fireproof cabinet is pressed by the mounting bracket.

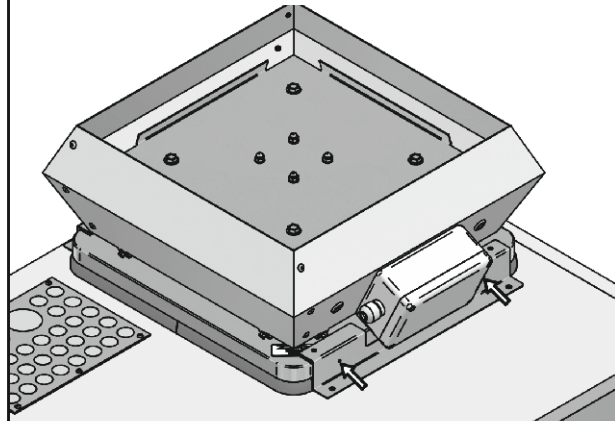

9 The completely assembled fan on the cabinet

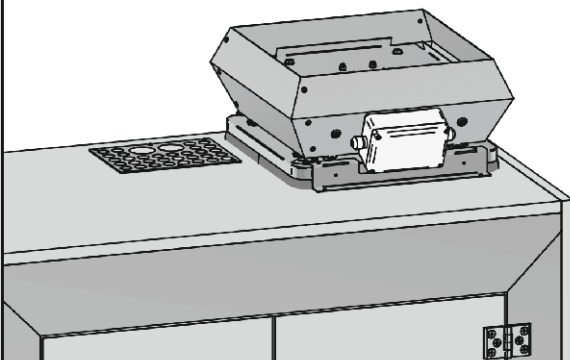

10 Maintenance information

The proper attachment of the fan using the mounting set must be regularly checked at least every six months.

11 Connecting the DVS roof fan with a high rpm

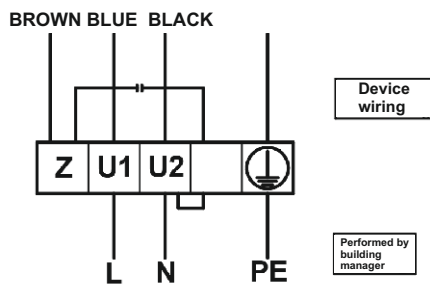

Information on the electrical connection for the fan

The wiring plan printed in the lid of the terminal housing must be considered for two different rpm speeds for the motor when providing the electrical connection.

12 Check completeness of content:

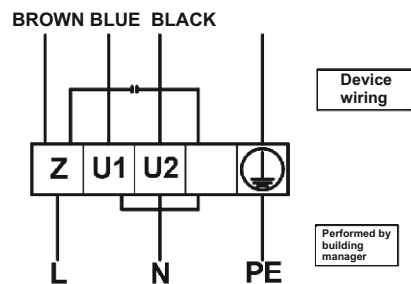

Information on the electrical connection for the fan

The wiring plan printed in the lid of the terminal housing must be considered for two different rpm speeds for the motor when providing the electrical connection.

Assembling the inner fan

1 Check that all the accessories are present

What is delivered:

- 1 x fan
- 1 x distancing plate
- 1 x attachment set for fan
(4 - 3.5 x 54 screws)
- 1 x attachment set for distancing plate
(4 - 3 x 25 screws)

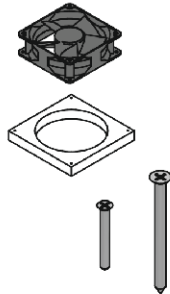

Tools required:

- Cordless screwdriver with suitable drill (\varnothing 2.5 mm) and top part (Phillips screw head)
- Pencil
- Small flat-tip screwdriver

2 Dismantle the filter cartridge

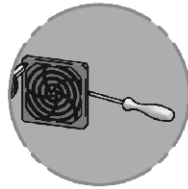

Carefully remove the cover and protection mat using a lever

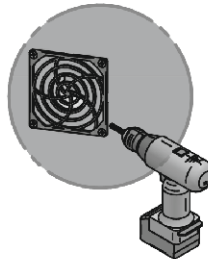

Loosen and remove all 4 screws

3 Pre-drill

Place the distancing plate in the middle under the fan opening and pre-drill attachment holes

Place the fan in the middle of the distancing plate and pre-drill attachment holes

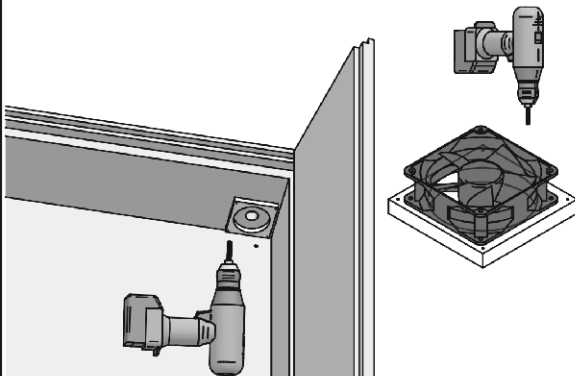

4 Attach the distancing plate

Attach the distancing plate in the drill holes that have been prepared

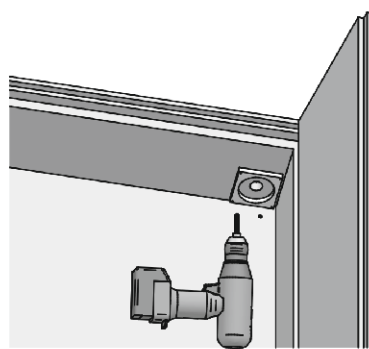

Beware: do not overtighten the screws!

5 Assemble the fan

Install the fan under the distancing plate and attach in the prepared drill holes.

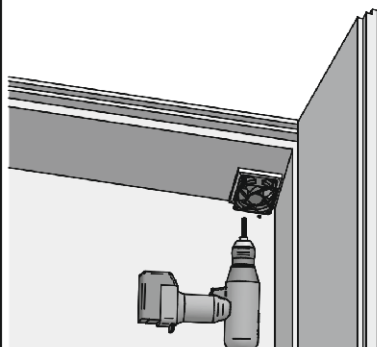

Beware: do not overtighten the screws!

6 Final check

Then complete a final check of the assembly work



- Is the fan below the envisaged opening?
- Are all the screws tight?

Dismantling takes place in reverse order!

Assembling the outer fan

(LLG 1-fan)

1 Check that all the accessories are present

What is delivered:

1 x LLG 1 fan
1 x attachment set for fan
(4 – 4.2 x 22 screws)

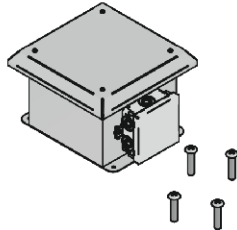

Tools required:

Cordless screwdriver with suitable drill (2.5 mm)
and top part (Phillips screw head)
Pencil
Small flat-tip screwdriver

2 Dismantle the filter cartridge

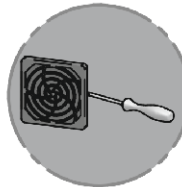

Carefully remove the cover and protection
mat using a lever

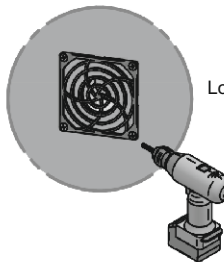

Loosen and remove all 4 screws

3 Drill markings

Place the fan on the top of the cabinet centrally above the
ventilation opening and prepare markings for drill holes

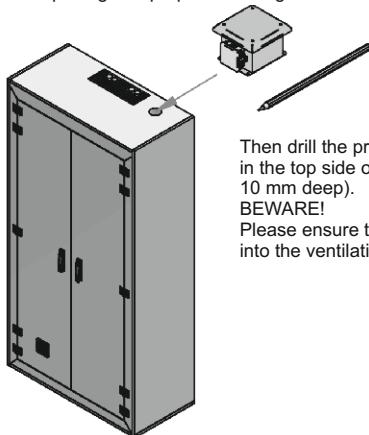

Then drill the pre-marked holes
in the top side of the lid (approx.
10 mm deep).
BEWARE!
Please ensure that no dirt gets
into the ventilation system!

4 Assembly

Place the fan on the top of the cabinet and
screw it in

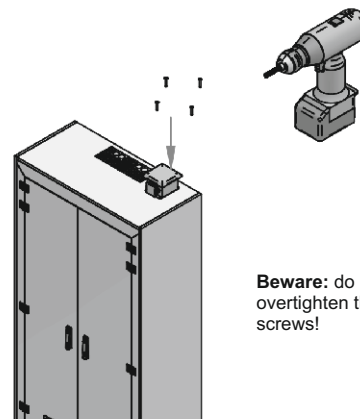

Beware: do not
overtighten the
screws!

5 Final check

Then perform the final check on the assembly work.

-Is the fan above the envisaged opening?

-Are all the screws tight?

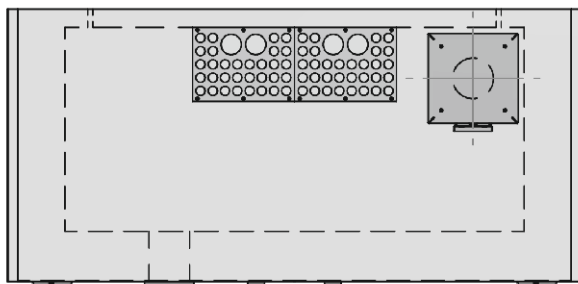

6

Dismantling takes
place in reverse
order!

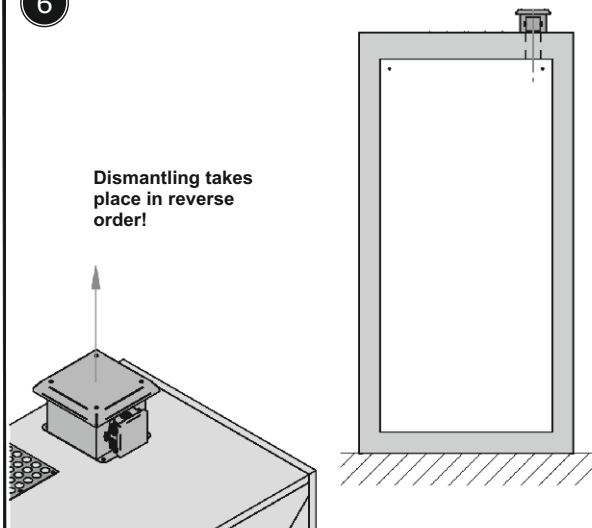

Assembling the outer fan

(RLS 230 V)

1 Check that all the accessories are present

What is delivered:

RLS 230 V
Attachment materials
1 cartridge of "Crystal Cel" fireproof cement
8 adhesive pads

Tools and accessories required:

Drill with suitable bit, pencil, screwdriver, cordless screwdriver, connecting cable (max. 1.5 mm²)
(Adapt fuse!)

Please note that the fire resistance capability of the fireproof cabinet is only guaranteed if the fireproof cabinet is always maintained in the condition prescribed in the certificate of suitability.

2 Mark the attachment drill holes

The covering flap and the black mat on the filter cartridge have to be removed.

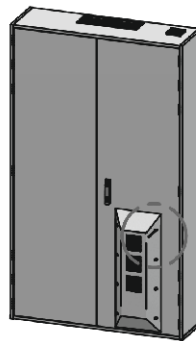
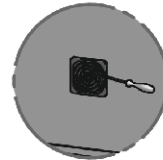

The RLS 230 V fan is then held up against the fireproof cabinet and the drill holes are transferred to the door panel using the pencil.

Important: the smoke alarm must be positioned above the ventilation system!

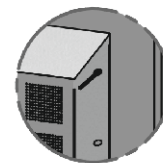

3 Pre-drill the attachment drill holes

The transferred markings are pre-drilled with a max. \varnothing 2.5 mm drill and 18 mm deep. A further through hole (\varnothing 8 mm) needs to be created at the same level as the connecting terminal for feeding through the connecting cable.

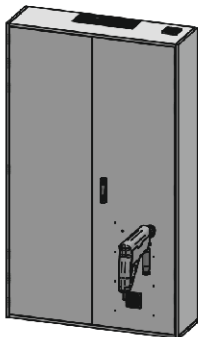

4 Feed through the connecting cable

To supply the fan with electric power, the cable (max. 1.5 mm²) is then fed through the door panel inside the cabinet. The cable must not be under tensile pressure inside and laid in a loop so that it does not snap off when the door is opened.

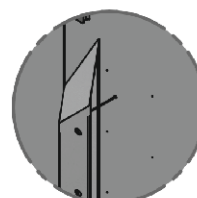
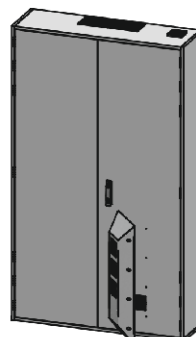

5 Attach the fan plate to the door panel

The fan plate is attached to the door panel using the enclosed attachment material.

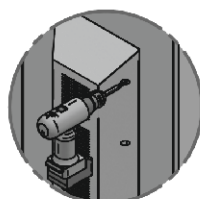
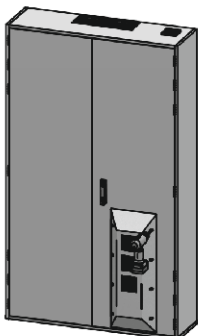

6 Completion and final check

The drill hole for the cable is sealed from the inside using the "Crystal Cel" fireproof cement to make it smokeproof.

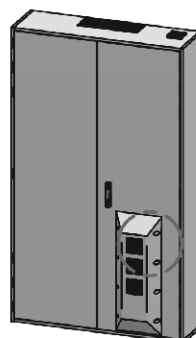

The adhesive pads that are supplied are then attached to the drill holes in the fan plate.

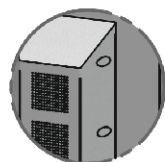

Assembling the outer fan

(RLS 230 V)

7 Feeding the cable to the cable transition unit

Feed the connecting cable in the flexible cable transition unit

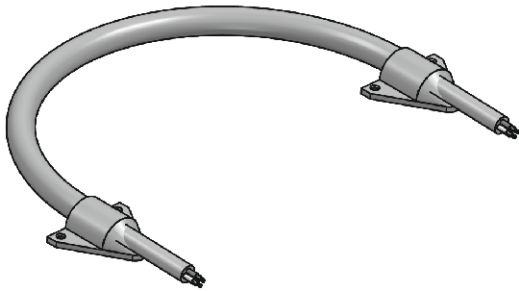

8 Seal the through drill hole

Seal the through drill hole from inside to make it fireproof.

We recommend:
Celsion **CRYSTAL-CEL Z.-19.11-1956**

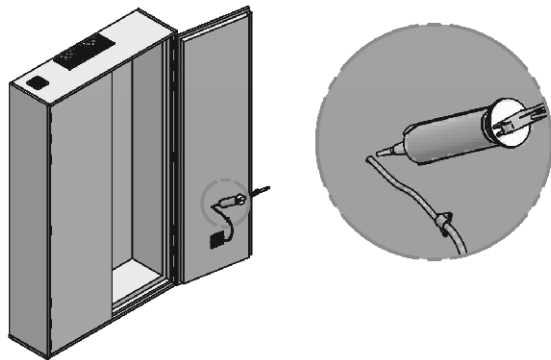

9 Attach the cable transfer unit

Assemble the cable transfer unit using the enclosed attachment material.

Beware: the connecting cable must not be subject to any pressure when the cabinet is opened.

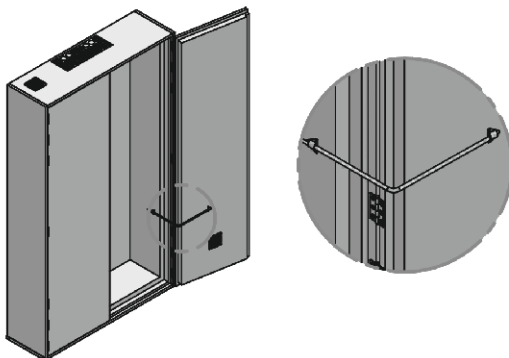

10 Check that the cabinet closure mechanisms shut properly

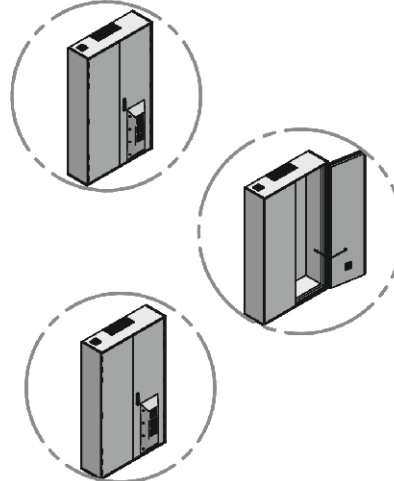

11 Screw coverings for the fan plate

The adhesive pads that are supplied are finally placed on the drill holes in the fan plate.

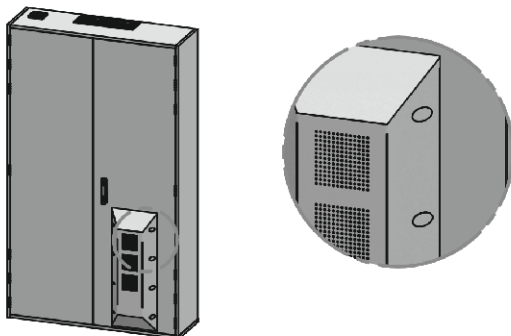

12 Final check

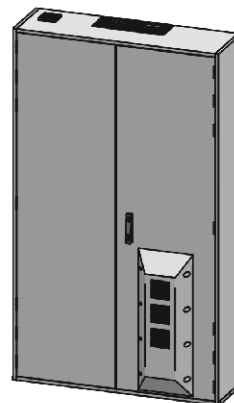

Fans and their key technical data

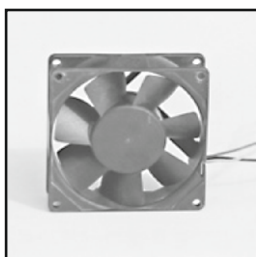

Fan for interior assembly

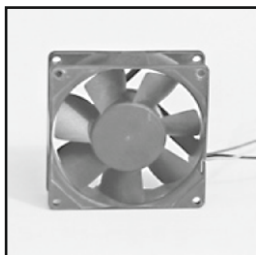

Fan for interior assembly

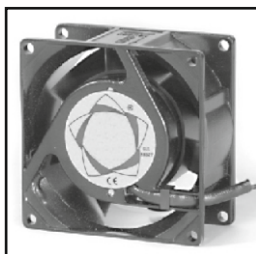

Fan for interior assembly

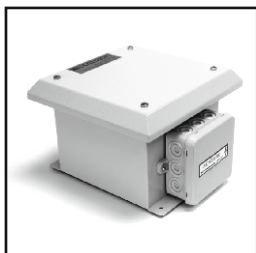

LLG 1 alpha for outside assembly



DVS for outside assembly



RLS for door assembly

12 V - fan model - 12 V DC

Outer dimensions: 119 x 119 x 25.5 mm
 Weight: 180 g / noise level: 54 dB (A)
 Power consumption: 6.6 W/h at 0.72 A/h
 Flow rate: 195 m³/h
 Protection class II
 Operating hours: L₁₀/ $<25^{\circ}\text{C}$ approx. 30,000 h
 Temperature range $>40^{\circ}\text{C}$ approx. 25,000 h
 (Article no.: 600067)

24 V - fan model - 24 V DC

Outer dimensions: 119 x 119 x 25,5 mm
 Weight: 180 g / noise level: 53 dB (A)
 Power consumption: 6,96 W/h at 0.38 A/h
 Flow rate: 195 m³/h
 Protection class II
 Operating hours: L₁₀/ 25°C approx. 50.000 h
 Temperature range $>40^{\circ}\text{C}$ approx. 25,000 h
 (Article no.: 600073)

230 V – Interior fan model - 230 V AC

Outer dimensions: 80 x 80 x 38 mm
 Weight: 340 g / noise level: 35 dB (A)
 Power consumption: 18 W/h at 0.09 A/h
 Flow rate: 51 m³/h
 Protection class I
 Operating hours*: L₁₀/ $<40^{\circ}\text{C}$ approx. 37.500 h
 Temperature range $>40^{\circ}\text{C}$ approx. 27.500 h
 (Article no.: 600068)

230 V – Interior fan model - LLG 1 - 230 V AC

Outer dimensions: 119 x 119 x 38 mm
 Weight: 550 g / noise level: 51 dB (A)
 Power consumption: 15 W/h at 0.12 A/h
 Flow rate: 150 m³/h
 Operating hours*: L₁₀/ 25°C approx. 30,000 h
 (Article no.: 600070)

LLG 1 alpha - 230 V AC fan

Outer dimensions: 192 x 176 x 120 mm
 with external rotor – shaded pole motor
 Surge protection through impedance protection
 Cabinet and fan wheel made of metal
 Weight: 1,5 kg / noise level: 65 dB (A)
 Power consumption: 15 W/h at 0.12 A/h
 Flow rate: 150 m³/h Frequency: 50 Hz
 Protection class I
 Operating hours*: L₁₀/ 25°C approx. 30,000 h
 (Article no.: 600065)

DVS Bafu – roof fan model 230 V AC

Outer dimensions: 370 x 419 x 175 mm
 Weight: 9 kg / noise level: 77 dB (A)
 Flow rate: ca. 820 m³/h Frequency: 50 Hz
 Power consumption: 113 W/h at 0.85 A/h
 Blows out air vertically, with flat design
 Protection class I; protection type IP 42
 Operating hours*: L₁₀/ $<40^{\circ}\text{C}$ approx. 30,000 h
 (Article no.: 600066)

RLS smoke alarm/ventilation system

Model: 230 V AC
 Outer dimensions: 785 x 304 x 86 mm
 Weight: 6 kg / noise level: 63 dB (A)
 Power consumption: 45 W/h at 0.36 A/h
 Flow rate: 150 m³/h
 Operating hours*: L₁₀/ 25°C approx. 30,000 h
 [Article no.: 600080 (no smoke alarm) / Article no.: 600078 (with smoke alarm)]

* In normal operating conditions

Please note that the insertion and surrounding conditions can markedly reduce the operating life of the fans

Assembly instructions

Smoke alarm – slider system

Note the necessary interior depth in the system.

1 Check that all the accessories are present

What is delivered:

- 1 x operating instructions
- 2 x U-sections
- 1 x retaining plate
- 1 x stopper plate
- 2 - 4.2 x 22 mm screws
- 2 - 3.5 x 19 mm screws
- 1 x drilling template
- 1 x attachment set for smoke alarm
(2 - M4 x 15 screws, 2 x washers, 2 x M4 nuts)

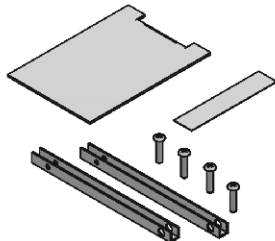

Tools required:

Cordless screwdriver with suitable drill (\varnothing 3 mm) or top part (Phillips screw head)

2 Make the attachment drill holes

Place the drilling template on the inside of the lid according to the drawing and make markings for drill holes.

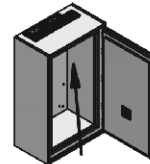
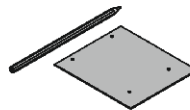

Then drill the pre-marked holes in the inside of the lid (approx. 10 mm deep).



*Note

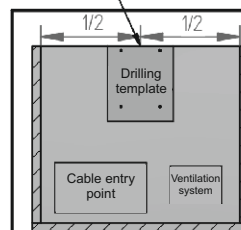

Rear wall

3 Fasten stopper plate and U-sections

Position the stopper plate and U-sections and attach to the side facing the door using the shorter screws (3.5 x 19 mm).

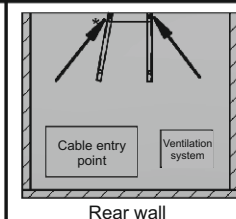

Rear wall

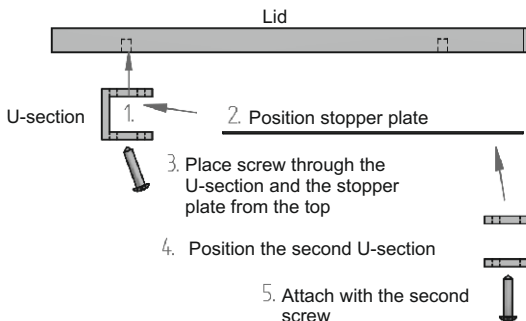

4 Insert the retaining plate

Carefully turn the U-sections to the side and insert the retaining plate.

Please note: the metal sheet must be facing upwards!

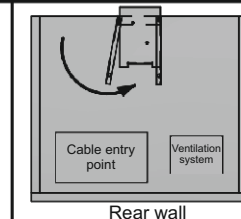

Rear wall

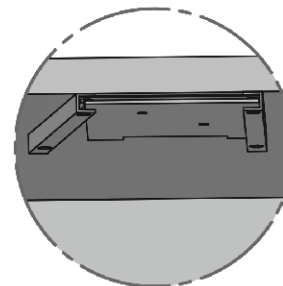
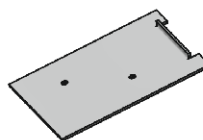

5 Attach U-sections

Carefully turn the U-sections into position and attach them using the longer screws (4.2 x 22 mm).

Please note: do not overtighten the screws!

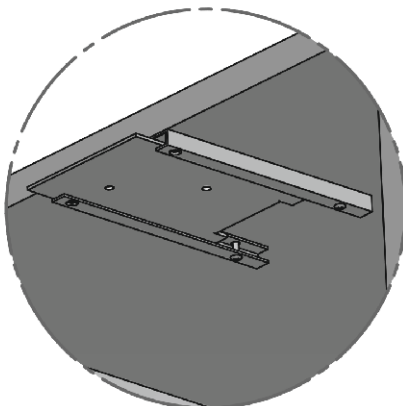

6 Mount the smoke alarm

Attach the smoke alarm according to the manufacturer's instructions.

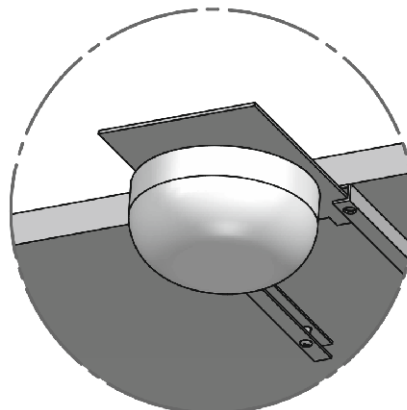

*Please note: depending on the series, the door may protrude into the interior space. In this case, assembly must not take place flush with the outer edge of the inner frame.

Additional equipment and accessories

We can offer you an extensive range of enhancement options for our fireproof systems to provide extraordinary problem solutions too.

If you have any questions about these products, please contact us directly.

Design, operations, mode of action

The fireproof systems consist of coated, non-metallic, panel-shaped components. The cabinet is not earthed.

The fire insulation is provided by processing the basic fireproof panels.

The door design on the free-standing and wall cabinets consists of a door with an opening angle of up to 180 degrees. The door is locked using a rotating lever lock with an integrated cylinder and a two-way key. It is possible to replace the cylinder.

The cable ducts have a fire resistance time of more than 30 or 90 minutes, depending on the model, if they are inserted properly, and have a surrounding seal to prevent any smoke escaping. Heat cannot enter via the cables because of special heat-consuming, chemical reactions.

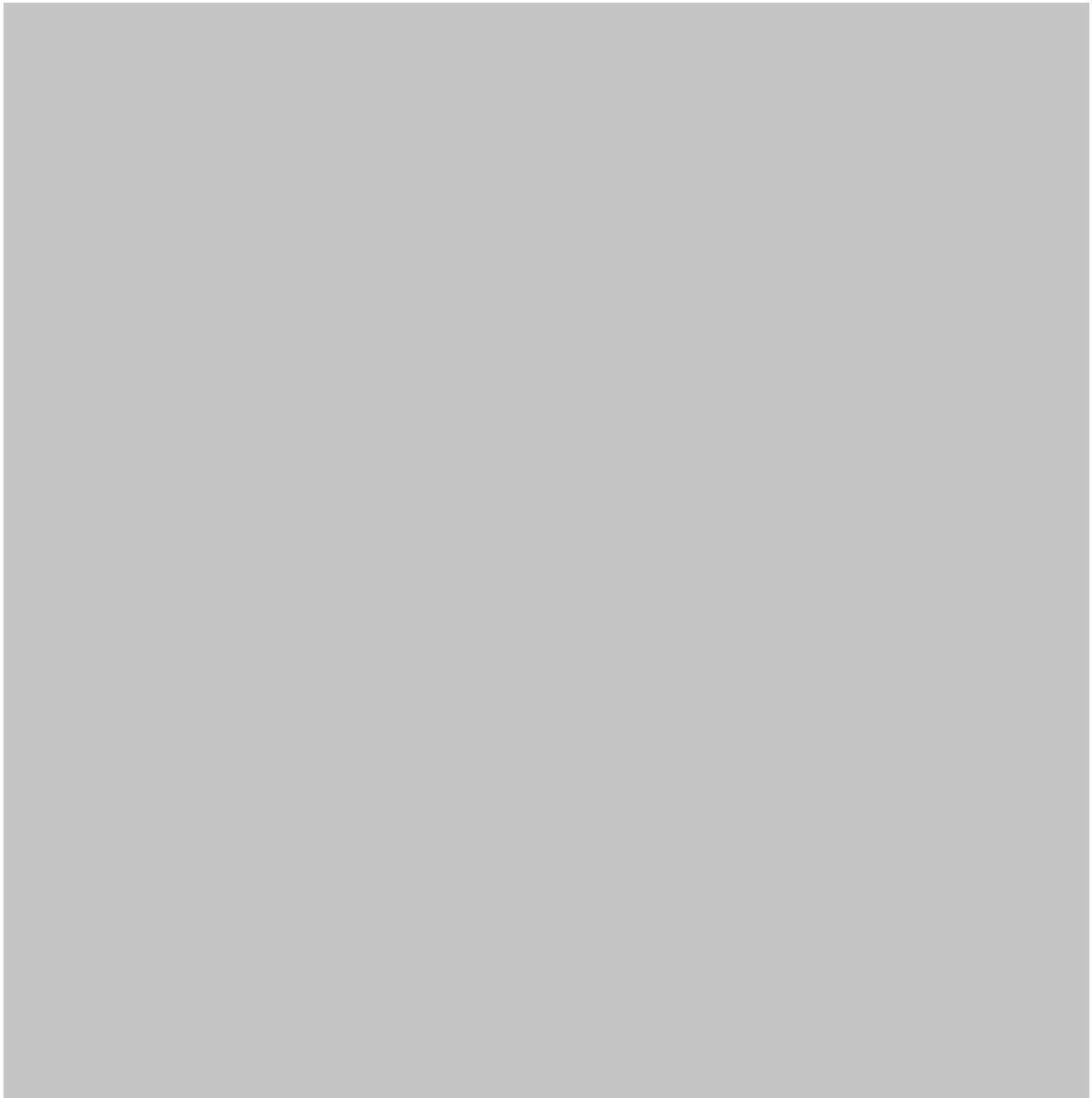

Assembly equipment

(Crystal-CEL fireproof cement)

Celsion - Crystal-CEL fireproof cement

Technical product data and features

Colour	Grey-brown
Viscosity	Paste-like
Bulk density	1750 kg/m ³ ± 100 kg/m ³
Expansion behavior	1:1,5 - 1:5,5 (450°C under pressure)
Max. gap size	15 mm
Distension pressure	1,3 N/mm ² - 3,0 N/mm ² (350°C)
Solids content	94 weight% (105°C)
Elasticity	Hardly elastic after drying
Skin formation	After about 10 min (at 23°C, 50 % RH)
External factors (climate)	UV-resistant
Building material class	A2 - s1,d0 (non-combustible) acc. to EN 13501-1
Storage	Store in a cool and dry place, protect from frost and heat
Processing	Do not use below +5°C
Storage period	12 months from filling date in original, sealed cartridge
Storage conditions	Store cartridges at +20°C
Delivery form	In plastic cartridge, 310 ml

Article-no.: 600025



Product description:

The Celsion Crystal-CEL fireproof cement is a building material that forms an insulating layer and complies with the A2 – s1, d0 building material class (non-combustible, no smoke formation, no dripping). The intumescent fireproof mass has extraordinarily good expansion behaviour in a fire. Crystal-CEL has the handling properties of acrylic paste.

Usage:

Crystal-CEL is suitable for sealing cables, metal pipes, joints and hollow spaces. It can be used to provide a seal against fire and smoke penetration. Crystal-CEL is used to seal connecting joints, e.g. for fireproof covers, walls or door designs and can be used to seal holes, cracks, small openings and gaps.

Handling it:

The substructure must be stable and free of dust, grease and oil (slightly moisten concrete or masonry). The required backfill material like mineral wool must be firmly stuffed into the opening (provide joints with mineral wool, for example). Do not use if the substructure or ambient temperature is below +5°C. Press Celsion fireproof cement directly into the joint and smooth it. Perform the smoothing work with a trowel moistened with water before a skin forms.

We are happy to send you the safety data sheet.

Manufacturer:

Celsion Brandschutzsysteme GmbH, Dresdener Str. 51, D-02625 Bautzen,
Phone: +49 (0) 3591 / 270 78 - 0, Fax: +49 (0) 3591 / 270 78 - 19, E-mail: office@celsion.de

 **CELSION**[®]
Brandschutzsysteme GmbH

**Please note general
building supervision permit
Z-19.11-1956**

Mark of conformity:



Celsion type fire-resistant distribution boards

Maintenance checklist for models

Series number:

Date:

The individual criteria must be checked; add a tick to confirm that they work properly.
Please sign and keep the checklist.

Test person /
signature:

List of tasks for checking distribution boards

Checklist	OK		OK
Has the assembly site been chosen to ensure that the fireproof requirements can be fulfilled? Visual check!		Temperature at the setup site: _____ °C	
Are the building panels undamaged? Is any corrosion damage visible? Visual check!		Are any gaps between the building panels larger than 1 mm? Visual check!	
Are all the screws in place? Visual check of screw holes!		Are the gaps in the door even with the frame or does the door drag on the frame?	
Is there a key available? Visual check!		Is the warning and maintenance information with the Celsion logo glued at the top right of the door? Visual check!	
Is the mark of conformity present?		Is the rating plate/production sticker glued at the top right of the cabinet? Visual check!	
Temperature in the proof cabinet at approx. 2/3 height: _____ °C		Is the heat development inside the cabinet below the defined threshold when the cabinet is closed? Detection level of power loss!	
Have the assembly and operating instructions been stored in the cabinet? Visual check!		Are the fireproof dowels in the cabinet and do they match the building material? Visual check!	
Is the rotating lever firmly attached? Visual check!		Does the lock/locking system close and lock? Functional check!	
Has the frame been correctly mounted? Does the door fit tightly? Visual check!		Is the flexible seal around the doors in a perfect state? Functional check! If necessary, attach or renew!	
Do the doors close tightly enough to keep dirt away? Are any seals in flaps and doors damaged?		Is the air feed inside the cabinet (air channel) free and open? (Pollution?) Measure pressure (e.g. with vacuum cleaner)	
Is the foaming sealing material arranged in the input/exhaust openings? Visual check!		Are the automatically closing feed and exhaust air openings open and undamaged? Visual check!	
Are the black filters still working? Order number: available on request; functional check/visual check!		Is the foaming fireproof seal in the door frame glued and undamaged all round? Visual check. If necessary, attach or renew!	
Are the fans working properly?		Is the DVS roof fan sealed with silicone all around?	

We recommend an annual check (ventilation systems at least every six months) and note the test intervals in building law.

You will find the maintenance checklist for printing at www.celsion.de/download/kataloge.

Celsion type fire-resistant distribution boards

Maintenance checklist for models

Series number: **Date:**

The individual criteria must be checked; add a tick to confirm that they work properly. Please sign and keep the checklist.

Test person / signature:

List of tasks for checking distribution boards

Checklist	OK		OK
Has the ventilation grille with the filter mat been removed below the outer fan?	<input type="checkbox"/>	Please replace the fan every 3 years. Order number: available on request Functional check/visual check!	<input type="checkbox"/>
Is the cable sheathing in a perfect state? Have the cables been fed in according to the specifications (dimension; free of pressure)? Visual check!	<input type="checkbox"/>	If the distribution boards are absolutely full (without any appreciable reserves), beware of overload phenomena in the form of excessive heat generation. This occurs particularly often if the distribution board components (switch cabinets, fuses, terminals, etc.) have "grown" with the unit, but not the distribution board itself. If the distribution board was designed according to DIN EN 61439, there is a measurement load factor that is normally 0.6 with more than 10 electric circuits. If the distribution board, however, has been increasingly expanded through extensions and changes and therefore subjected to stress, this inner wiring may be overloaded. The ambient temperature of 40°C may be exceeded in a distribution board and therefore jeopardise the proper functioning of all the operating materials.	<input type="checkbox"/>
Are the cables and wires attached properly? Are they fed in from below? Ensure that they are correctly secured!	<input type="checkbox"/>		
Are the bending radii on the wires correct?	<input type="checkbox"/>		
Ensure that no moisture (condensation) forms inside, particularly with distributors with compact, completely encapsulated cabinets (e.g. with IP 54 protection)!	<input type="checkbox"/>		
Watch out for any interaction! (e.g. falling parts, moisture, oscillation etc.)	<input type="checkbox"/>		

Notes/remarks

Celsion type fireproof distribution boards

Possible measurement tasks on distribution boards

Series number:

Date:

The individual criteria must be checked and confirmed that they work properly by adding a tick. Please sign and keep the checklist.

Test person /
signature:

List of measuring tasks with distribution boards

Checks	OK
<p>1. Temperatures with a contact-free infrared thermometer: this unit makes it possible to perform a quick measurement very simply. The measurement must be taken during operations. The unit should have a radius of action that is as small as possible so that reliable results are still possible at a distance of 20 – 50 cm. The diameter of measured surfaces should not exceed 0.5 – 1,0 cm with these distances. Dangerous heat development can be discovered particularly next to or near terminals or switch housings. These measurements are naturally only snapshots and, depending on the distance of the infrared thermometer, not fully accurate, because mixed temperatures from the complete measured surface will play a role at any time.</p>	
<p>2. Temperatures: If there is a special risk, but otherwise too, a thermographic investigation is highly recommended from time to time. Thermographic cameras are used for this measurement to record heat images of the distribution board during operations. This reveals where any dangerous heat formation is taking place. This measurement is far more accurate than when using an infrared thermometer, as mentioned above. However, there are disadvantages: this measurement can really only be performed by trained personnel, as these heat images have to be precisely interpreted. The camera should only be operated by experts too.</p>	
<p>3. Insulation test: All the active conductors should be measured at various points against the PE rail (or terminal) or against the housing on distribution boards with protection class I. The latter is only possible on distribution boards with protection class II if the housing (outer or inner) also has metallic components. It may therefore make sense to check the insulating condition of the supply cable completely with the connected distribution board. The outflow from the distribution board should not be connected for this. This kind of measurement is often not possible, as the whole area that the distribution board supplies with electrical energy has to be disconnected. However, if there is any uncertainty, these kinds of check are necessary. If it is possible to check the insulation of a distribution board, consideration should be given on whether it is possible to select a voltage check at 1,000 V (instead of 500 V) from the outset, as this can provide a meaningful test. If the distribution board has any surge arrestors, they should be disconnected for this.</p>	
<p>4. Surge voltage strength test: It gives voltage input with several kV to the distribution board and checks its insulation state. The test very realistically reflects the stresses that occur in a distribution board. There are special measuring devices on the market for this.</p>	
<p>5. Neutral conductor current: This measurement uses a current clamp. However, it needs to be a current clamp that measures the "real effective figure" to be able to measure correctly if any harmonics currents occur.</p>	

We recommend at least an annual check of the points listed above.

Storage and environmental conditions

To enable full functions and a long serviceable life for our products, we would ask you to note the following points for intermediate storage, setup and assembly work and comply with them:

- Do not store or set up outside
- Protect unit from moisture, rain, spray water and weather conditions
- Do not store below 10°C/above 40°C (according to DIN EN 61439-1)
- Do not store or set up in rooms with air humidity levels of more than 50% (according to DIN EN 61439-1),
- Do not expose to any frost
- Leave fireproof distribution boards and wall attachment doors on transport pallets
- Do not stack (stacking caused by transport takes place at the factory and does not impair the functions in the systems)
- Do not subject to loads (stacking caused by transport takes place at the factory and does not impair the functions in the systems),
- Only store and set up on solid, even ground
- Comply with the instructions and specifications when having the unit assembled by authorised employees or partner companies of Celsion Brandschutzsysteme GmbH



If you have any questions about storing or setting up our products, we are more than happy to help you; please contact us on the following number:

Manufacturer:

Celsion Brandschutzsysteme GmbH, Dresdener Str. 51, 02625 Bautzen, Germany
Phone: +49 (0) 3591 / 270 78 - 0, Fax: +49 (0) 3591 / 270 78 - 19, E-mail: office@celsion.de

Manufacturer's declaration

Valid for all series

The specifications, guidelines, standards etc. listed in these assembly and operating instructions match the latest information that we had when preparing this document. The operator must use the latest, valid version of them at its own responsibility.

The requirements in the relevant certificates of suitability must be noted too. Permissible and minor discrepancies in the product designs must be taken into consideration in this process.

Some safety-related units related to the Federal State Building Order must be inspected and approved by an expert according to Sections 27 and 35 of the Implementation Order after being set up, e.g. on the basis of the Saxon Building Regulations.

The manufacturer (Celsion Brandschutzsysteme GmbH) can change the data and specifications used in these assembly and operating instructions at any time without specifying any reasons. These instructions have been prepared with great care and the contents have been drawn up to the best of our knowledge. Errors cannot be excluded and improvements are possible.

We do not assume any liability for ensuring that the content complies with the latest statutory provisions.

The copyright for these assembly and operating instructions and all the rights associated with the issue of a patent or entering a registered design remain with the manufacturer.

Disclaimer

All previous editions of these assembly and operating instructions lose their validity on the data that these appear. We have compiled this catalogue and the descriptions in it and all the technical information and explanations with great care. Despite this, we cannot assume any liability for typesetting or printing errors, technical changes in the products or our ability to deliver items during the time of the catalogue. Illustrations and descriptions in this catalogue do not represent guaranteed features in any case. All the dimensions listed are nominal sizes. Discrepancies in sizes may lie within tolerances of + / - 5 mm, depending on the model and design.

The customer's responsibility

The customer is responsible for correctly using the unit according to the building rules for its own products. The assessment on whether the units being inserted remain able to function lies with the customer. We are happy to help you in this assessment by providing approximate calculations. Project-related surveys may be necessary for particular designs.

The relevant certificates of suitability must be requested for your project. Important information is also available from the technical documentation that is available. In cases of doubt, we are happy to advise you.

Please contact us as follows:

Phone: + 49 (0) 3591 / 270 78 - 0 | Fax: + 49 (0) 3591 / 270 78 - 19 | E-mail: office@celsion.de

You will find the latest information and instructions and the General Terms and Conditions of Business on our home page: www.celsion.de

Correct in: May 2021



If you have any problems, please phone our customer service department on +49 (0) 3591 / 270 78 - 0.

You can reach us on Monday - Thursday 8 a.m. – 4.30 p.m. and Friday 8 a.m. – 2 p.m.

Assembly & Operating Instructions

Correct in May 2021 for planners, architects, specialist companies
The latest information on account of the updating of the MBO has sometimes been taken into consideration.



Visitor and delivery address

Celsion Brandschutzsysteme GmbH
Dresdener Str. 51
D-02625 Bautzen
T: +49 (0)3591 / 27978 - 0
F: +49 (0)3591 / 27978 - 19
E-Mail: office@celsion.de

Technical office in Munich

Celsion Brandschutzsysteme GmbH
Ohmstraße 3, 2.OG
D-85716 Unterschleißheim
Tel.: +49 (0) 89 / 720 577 - 20
Fax: +49 (0) 89 / 720 577 - 22
E-Mail: office@celsion.de

Technical office in Dresden

Celsion Brandschutzsysteme GmbH
Cäcilienstraße 5
D-01219 Dresden
Tel.: +49 (0) 351 / 272 046 - 0
Fax: +49 (0) 351 / 272 046 - 29
E-Mail: office@celsion.de

General Manager

Boris Schubert
Amtsgericht Dresden HRB 27622
Place of jurisdiction is Dresden
USt-IdNr.: DE 813249551
Tax identification number: 203 / 107 / 17984

www.celsion.de

